

**The Pennsylvania State University**

**The Graduate School**

**College of Agricultural Sciences**

**AN INTEGRATED *IN VITRO* AND GREENHOUSE ORTHOTROPIC  
CLONAL PROPAGATION SYSTEM FOR *THEOBROMA CACAO* L.**

A Dissertation in

Horticulture

by

Carter R. Miller

© 2009 Carter R. Miller

Submitted in Partial Fulfillment

of the Requirements

for the Degree of

Doctor of Philosophy

May 2009

The dissertation of Carter R. Miller was reviewed and approved\* by the following:

Mark J. Gultinan

Professor of Plant Molecular Biology

Dissertation Advisor

Chair of Committee

Siela Maximova

Senior Research Associate

David M. Eissenstat

Professor of Woody Plant Physiology

Robert M. Crassweller

Professor of Tree Fruit

Roy E. Young

Professor of Agricultural and Biological Engineering

Richard Marini

Professor of Horticulture

Head of the Department of Horticulture

\*Signatures are on file in the Graduate School.

## ABSTRACT

Two novel methods are described to stimulate intensive and sustained orthotropic (vertical, juvenile) shoot production in softwood and semi-hardwood *Theobroma cacao* L. stock plants, derived from tissue culture of floral staminodes via primary and secondary somatic embryogenesis.

The first stock plant method consisted of development of softwood stock plants in a bench top modified hedge. Harvest of orthotropic shoot material began two months after acclimation in the greenhouse and utilized periodic light pruning of orthotropic softwood shoots (chupons, suckers or water sprouts). This high-intensity propagation method yielded 70 stem cuttings per softwood stock plant per year, approximately 1,250  $\text{m}^{-2}\cdot\text{year}^{-1}$ . Single and few node orthotropic stem cuttings were rooted under intermittent mist. The propagation efficiency (percentage of plants produced per stuck cutting) from softwood stock plants ranged from 66% to 81%. Under the specific conditions of the current study, the estimated production of orthotropic rooted cuttings from softwood stock plants maintained as a bench top clonal garden was estimated to range between 825 and 1,012 rooted cuttings  $\text{m}^{-2}\cdot\text{year}^{-1}$ .

The second orthotropic shoot production method involved the bending to horizontal of the main trunk of semi-hardwood stock plants from 9 to 12 months after acclimation, release of axillary and adventitious orthotropic meristems from the bent trunk, and repeated harvest by periodic light pruning of orthotropic shoots for rooting material. Using the bending method, semi-hardwood stock plants yielded on average over 300 single and few node orthotropic stem cuttings per year, or approximately 500  $\text{m}^{-2}\cdot\text{year}^{-1}$ .

$\text{m}^{-2}\cdot\text{year}^{-1}$  at the stock plant density tested. Single and few node orthotropic stem cuttings were rooted under intermittent fog. The propagation efficiency of rooted cuttings from semi-hardwood stock plants ranged from 68% to 74%. The estimated production of orthotropic rooted cuttings from bent semi-hardwood stock plants was estimated to range between 340 and 370 rooted cuttings  $\text{m}^{-2}\cdot\text{year}^{-1}$ .

Overall, the softwood orthotropic stock plants produced 1.5 times more plants per given unit of space and time than the bent semi-hardwood stock plants. Softwood stock plants are compact and have shorter chupons and leaf laminae, as well as smaller stem diameters in comparison to bent semi-hardwood stock plants. Production of softwood stock plants requires a higher level of cultural management and propagation technique than those for bent semi-hardwood stock plants. Utilization of softwood stock plants in the current study significantly shortened the time necessary for greenhouse multiplication of vegetatively propagated orthotropic cacao plants compared to the utilization of bent semi-hardwood stock plants.

Comparison of development at the juvenile stage in a climate controlled greenhouse demonstrated that primary somatic embryos ( $1^{\circ}\text{SE}$ ) and secondary somatic embryos ( $2^{\circ}\text{SE}$ ) grew true to type as compared to seedlings. As well, orthotropic rooted cuttings from softwood stock plants (RC-SW) and orthotropic rooted cuttings from bent semi-hardwood stock plants (RC-SHW) grew true to type. All four orthotropic vegetatively propagated trees had the characteristic jorquette (whorl of plagiotropic fan branches) at the phase change from the juvenile orthotropic trunk to the mature plagiotropic canopy morphology. RC-SW had a relatively longer juvenile phase, while RC-SHW had a more rapid transition to mature phase that was demonstrated by earlier

and lower formation of the jorquette. All orthotropic cacao trees had one or more tap roots (seedlings and SE plants) or their analog, orthogeotropic framework roots, (from an adventitiously -derived root system of rooted cuttings). SE plants and orthotropic rooted cuttings had lower leaf area (LA) per gram of dry weight (DW) of root and higher root to shoot ratio than seedlings, although LA per stem DW did not differ among plants. Photosynthesis measurements at 12 months in the greenhouse showed no difference between 2°SE and seedlings.

These orthotropic clonal propagation methods may be adopted by germplasm banks, international cacao research centers, universities, private laboratories, as well as regional and local extension services and nurseries for use in international, regional, and local distribution schemes for elite or other newly developed clonal varieties of cacao or other instances where original stock plant material is limited or the orthotropic seminal tree architecture is desired. The use of the bending technique for semi-hardwood stock plants may be of particular utility to nurseries and growers interested in robust, on-farm propagation of clonal varieties that have orthotropic tree architecture and an orthogeotropic adventitious framework root system similar to that of a seminal tree.

A single line of somatic embryo plants that were genetically transformed by cocultivation with *Agrobacterium tumefaciens* strain AGL1 and containing the EGFP and NPTII genes were acclimated to the greenhouse. Non-destructive growth measurements were taken to compare the transgenic line and non-transgenic 2°SE plants during 18 months. Growth analysis of plant height, stem diameter, number of leaves and leaf area, as well as photosynthesis and excised root respiration measurements did not indicate any differences in these parameters between transgenic and non-transgenic SE-derived plants.

EGFP expression was analyzed in seeds from two genetic crosses. One to one segregation of EGFP expression in the seeds indicated that the T-DNA was inserted at a single locus in this line.

## TABLE OF CONTENTS

LIST OF TABLES	xi
LIST OF FIGURES	xii
ACKNOWLEDGEMENTS	xiv
CHAPTER 1. AN INTRODUCTION TO CACAO PROPAGATION	1
Overview of Cacao Propagation by Seed	1
The Importance of Vegetative Propagation for Research and Cacao Production Systems	3
Comparative Field Trials of Seedlings and Rooted Cuttings	5
Dimorphism of Tree Architecture as Related to Conventional Vegetative Propagation, Field Management, and Performance	6
Cultural Methods to Overcome the “Shortcomings” of Plagiotropic Clones	8
Efforts to Promote Orthotropic Scion Material in Stock Plants	9
Field Performance of Orthotropic Rooted Cuttings and Grafted/ Budded Scions	11
Progress of <i>In Vitro</i> Applications to Vegetative Propagation	12
Complementarity of Biotechnology and Conventional Approaches for Vegetative Propagation	15
Outlook for Development of Orthotropic Stock Plants and Intensive High Density Orthotropic Clonal Gardens	16
Specific Objectives of the Study	18

CHAPTER 2. GREENHOUSE ESTABLISHMENT OF SOFTWOOD AND BENT SEMI-HARDWOOD ORTHOTROPIC STOCK PLANTS DERIVED FROM SOMATIC EMBRYOGENESIS AND PRODUCTION OF ROOTED STEM CUTTINGS	20
Introduction	20
Materials and Methods	25
<i>“In Vitro” Plant Material</i>	25
<i>Greenhouse Acclimation and Growing Conditions</i>	26
<i>Softwood Stock Plant Development and Rooting of Cuttings</i>	28
<i>Semi-Hardwood Stock Plant Development and Rooting of Cuttings</i>	30
<i>Experimental Design and Analysis</i>	31
Results	32
<i>Production of Orthotropic Stock Plants in Two High-Density         Somatic Embryo Derived Experimental Clonal Gardens</i>	32
<i>Softwood Stock Plant Development</i>	35
<i>Rooting of Cuttings from Softwood Stock Plants</i>	37
<i>Semi-Hardwood Stock Plant Development</i>	40
<i>Rooting of Cuttings from Semi-Hardwood Stock Plants</i>	42
<i>Transplant and Establishment of Cuttings</i>	43
Discussion	43
<i>Previous Results with Orthotropic Rooted Cuttings from SE Derived         Softwood Stock Plants</i>	43



<i>Previous Results with Orthotropic Cloning of Non-SE-Derived Semi-Hardwood Plants</i>	45
<i>Examination of Rooted Cutting Production and Extrapolation to a Clonal Garden Scale</i>	47
Chapter 3. DEVELOPMENT AND PHYSIOLOGY OF CLONAL CACAO: GREENHOUSE COMPARISON OF JUVENILE PLANTS FROM SOMATIC EMBRYOGENESIS AND ORTHOTROPIC ROOTED STEM CUTTINGS TO SEEDLINGS	49
Introduction	49
Materials and Methods	52
<i>Plant Material and Greenhouse Conditions</i>	52
<i>Experimental Design and Analysis</i>	53
Results	55
Discussion	71
<i>General importance of dimorphism to cloning and consequences for orthotropic clones</i>	71
CHAPTER 4. STABLE TRANSFORMATION OF <i>THEOBROMA CACAO</i> L. AND INFLUENCE OF MATRIX ATTACHMENT REGIONS ON GFP EXPRESSION	78
Abstract	79
Introduction	80
Materials and Methods	82

<i>Vector Construction</i>	82
<i>Tissue Culture and Genetic Transformation</i>	84
<i>Plant Acclimation</i>	86
<i>Growth Measurements</i>	87
<i>Pollination Method and Gene Segregation Analysis</i>	87
<i>GFP Visualization</i>	88
<i>Genomic PCR Analysis</i>	89
Results and Discussion	91
<i>Transgenic Embryo Formation and Transformation Efficiency</i>	91
<i>Transgenic Plant Conversion, Growth, and Gene Segregation Analysis</i>	97
<i>Growth and Maturation of Transgenic Plants</i>	98
<i>Transmission of GFP Expression through Sexual Reproduction</i>	99
<i>Stability of GFP Expression Level</i>	100
<i>Molecular Analysis of Transgene Insertion into the Genome</i>	105
Acknowledgements	108
References	108
CHAPTER 5. CONCLUSIONS AND FURTHER RESEARCH	113
LITERATURE CITED	120

## LIST OF TABLES

Table 2.1. Production of orthotropic softwood stem cuttings from softwood stock plants	37
Table 2.2. Adventitious rooting of softwood orthotropic (chupon) stem cuttings from softwood and bent semi-hardwood stock plant types	38
Table 2.3. Production of single and few node softwood stem cuttings from bent semi-hardwood stock plants	42
Table 3.1. Juvenile growth of seedlings, somatic embryos, and orthotropic rooted cuttings at 4, 8, and 12 months	63
Table 3.2. Relative growth rates of juvenile growth of seedlings, somatic embryos, and orthotropic rooted cuttings between 4 to 8, and 8 to 12 months	67
Table 4.1. Transgenic secondary (TSSE) and tertiary embryos (TTSE) produced from ten <i>Agrobacterium tumefaciens</i> -mediated transformation experiments with three different binary vectors	94
Table 4.2. Comparison of the growth parameters of transgenic and control somatic embryo (SE)-derived plants after 5 months in the greenhouse	99
Table 4.3. Mean values of green fluorescent protein fluorescence intensity $\pm$ standard error and their variances	102

## LIST OF FIGURES

Figure 2.1. Flow diagram from <i>in vitro</i> plantlets through <i>ex vitro</i> softwood and bent semi-hardwood stock plants to rooted cutting production	27
Figure 2.2. Softwood SE-derived stock plant development and production of softwood orthotropic rooted stem cuttings	33
Figure 2.3. Semi-hardwood stock plant development and production of softwood orthotropic rooted stem cuttings	34
Figure 2.4. Adventitious rooting success over time of stem cuttings from softwood stock plants	39
Figure 2.5. Orthotropic chupon from bent semi-hardwood stock plant	41
Figure 3.1. Distribution of first jorquette height in rooted cuttings from chupons of semi-hardwood bent stock plants	56
Figure 3.2. Heading cut (tipping) applied to first jorquette, regrowth of orthotropic axis, and development of second jorquette	57
Figure 3.3. Bare root juvenile orthotropic plants and plagiotropic rooted cutting at four months growth in greenhouse	59
Figure 3.4. Orthotropic trees and primary root systems after twelve months in the greenhouse	62
Figure 3.5. Allometric relationship of leaf area to total plant dry weight in juvenile orthotropic trees	70
Figure 3.6. Allometric relationship of root dry weight to total plant dry weight in juvenile orthotropic trees.	72

Figure 4.1. Structures of binary transformation vectors for <i>Agrobacterium tumefaciens</i>	83
Figure 4.2. Green fluorescent protein expression in cacao tissues and plants	92
Figure 4.3. Mean number of transgenic embryos produced and plant conversion rates from ten transformation experiments	95
Figure 4.4. Evaluation of green fluorescent protein fluorescence of control and transgenic tissues from multiple somatic embryo lines and mature cacao plants	101
Figure 4.5. Microscope images of the variation in green fluorescent protein (GFP) fluorescence intensity among different tertiary SEs from a single transgenic line containing the primary vector pGH00.0216	104
Figure 4.6. Genomic PCR analysis of non-transgenic and transgenic lines containing the EGFP gene	106

## ACKNOWLEDGEMENTS

As a young boy, I always found myself slipping into the creek behind my friend Pat's house, or getting stuck way up in the tree in the backyard, or happily sledding down Pine Hill with my brothers Bill, Rick, and sister Linda. I never imagined that my life would take the twists and turns that have led me to this special place. As a sapling that has the best soil, climate, and environment will have the best chance to bare the best fruit, so too I have received more than my share of nurturing and support that has helped this fruit of my education, a small sampling of which is contained in these pages, come to bare. I would like to thank all those people who have helped me arrive at this place.

Science class always intrigued me as a young student, and I would be remiss if I would not mention those teachers, known to me still only by their last names, whom I think of to the present day, Schindler, Oglesbee, Fix.

While still an undergraduate at the University of Oklahoma, I was fortunate enough to find myself in General Botany taught by now botany and microbiology department chair Gordon Uno. I never looked at another plant the same way after that and soon enrolled in Plant Systematics, an odd choice for an undeclared letters major. Systematics was taught by who would become my undergraduate advisor, Wayne Elisens.

After ditching my ride with one of Wayne's graduate students on an entirely unsuccessful collection trip in remote Arizona at noon on an August day, I began to walk and hitchhike my way back home to Oklahoma. One ride left me on the top of a canyon that I began to descend at about 1:00 P.M., the sun pounding down and me with no water.

I found that plant right there as I was making my way down to the river, collected some seed, made it to water right in time, and caught another ride, eventually making it back home. I delivered those seeds to Wayne, and they grew in the botany greenhouse for me to measure.

It was in Plant Systematics that I met my later roommate and my longest botany colleague Peter Morrell. I would not have decided to declare as a botany major if it weren't for having met Peter, and we are friends to this day. Peter recently reminded me that a Ph.D. is a terminal degree. That's Oklahoma style humor.

I would like to thank other of my professors at OU who inspired me to inquire, observe, discover, and think critically, of whom I hold fond memories, Scott Russell, Lois Pfiester, John Fletcher, Linda Wallace, and Scott Collins.

Caryn Vaughn hired me at the Oklahoma Natural Heritage Inventory while I was an undergraduate and gave me my first taste of conservation research hunting for the prairie mole cricket. I have fond memories of my time there and lessons learned from Caryn and the other wonderful colleagues including Bruce Hoagland and Ian Butler.

Linda Watson gave me my first job after graduating with a B.S. in botany and taught me a dedication to detail that I carry with me until today. I still remember dissecting all those tiny floral pieces of *Eriocaulon koernickianum*.

In the fall of 1995, I found my way to University Park after receiving a reply to a letter (yes, it was paper back then) sent to Jonathan Lynch. My quest for knowledge led me to apply to the graduate program in plant physiology at Penn State University. Jack Shanon welcomed me to the program, and Jonathan became my advisor for the Master's

degree in Horticulture I would eventually obtain. I hold many fond memories of my time working in the plant nutrition lab. I met many truly wonderful people during that time.

Part of the experience as a graduate student is as teaching assistant. Here the old adage “one learns by teaching” came home. I would like to thank those for whom I taught and from whom I learned so much, Richard Craig, Michael Orzolek, and Marvin Pritts at Cornell University, as well as the many undergraduates and graduate student colleagues in my classes.

Also, it was my pleasure to have met and worked with some of the brightest minds, Xiaolong Yan, Terry Bates, Kristian Borch, Tjeerd Bauma, Jeannette Bajuelo, Ivan Ochoa, Taryn Bauerle, and Marc Goebel among them.

Andrew Riseman, another bright mind, has given me encouragement since knowing him, and I hold that dearly. A true friend and colleague.

A special person who will remain close to my heart always is Kai Nielsen. Digging up bean roots under the Costa Rican sun would not have been the same with anyone else, and I would not trade that experience, and all the others we have had along the way.

Thanks and appreciation go to the Department of Horticulture faculty and staff who have always been so supportive and facilitated my transition to Penn State and to and from Brazil. Jay Holcomb and Dennis Decoteau headed the department during my stay at University Park, and I appreciate their dedication to promoting my graduate studies. Kathleen Brown made sure that I would remain in my current program, and that was extremely kind of her. As well I cannot forget to mention Sharon Pishak and Ann Young, both who have always been so helpful in my times of need.



Neal Barto worked tirelessly and beyond the call of duty with me to ensure that these cacao trees, reported on in this work, received the exact growing environment I requested. Together Neal and I created a tropical environment where these plants flourished. Together we installed an automated irrigation system to nourish the plants day and night. But mostly Neal controlled the temperature, the relative humidity, and the intricate program upon which these plants depended for their survival in the depths of a Central Pennsylvania winter's night. Not one datum found in this dissertation would have been possible without Neal.

During this study, I have had the opportunity to interact with many professionals working in cocoa. Gregory Ziegler has always lent his ear, and his door has always been open to introduce me into the world of chocolate. Bertus Eskes has been likewise encouraging of the work done with orthotropic propagation. I would like to thank the members of the American Cocoa Research Institute Scientific Advisory Committee for their encouragement to a young scientist making his way into a new realm. Steve Lansing, Ken Miller, David Stuart, Vincent Petiard, and John Hammerstone always gave straightforward observations that were appreciated.

Since leaving University Park to live in Brazil, I have been welcomed by cocoa researchers there. Uilson Lopes and I have had many good conversations about cacao. I would like to thank Raul Valle and Alex-Alan Almeida for kindly reading and commenting on early versions of what would become chapters 1 and 2. It has also been my privilege to know the talented researchers, many whom I can call friends, Julio Cascardo, Fatima Alvim, Marcio Costa, Abelmon Gesteira, and Fabienne Micheli. José Claudio Faria kindly assisted with the statistical analysis in chapter 3.

In the cacao molecular biology laboratory, I had the real pleasure of working with many (at the time) undergraduate students, among them, Christine Sickler, Laurie Verost, Alex Lee, Nick Willis, Candice Thomas, Tom Hays, Matt Woll, Laura Troust, Molly Clancy, and Hugh Young.

I would like to thank my fellow graduate students and colleagues for their support and friendship, Erika Bareto (whose plants I adopted), J.D. Swanson, Abdoulaye Traore, Gabriela Antúnez de Mayolo Wilmking, and Jean-Philippe Marelli.

My dissertation committee, in forms past and present has helped to guide me through this long and perilous journey. I would like to thank John Carlson and Larry McCormick for their service and lessons given and hopefully learned. As well, I feel a sense of gratitude to Roy Young, who has graciously stepped in to help me through these last stages. Robert Crassweller and David Eissenstat have helped me by telling me to go back and try again, and, while that may have been a difficult pill to swallow, I see now that it was for the best. David Eissenstat went so far as to accompany me to the cacao region of south Bahia, Brazil when scouting for field sites. Siela Maximova has been always there for me when I needed any assistance, insight, or consultation. Thank you.

A special place is reserved for ones' dissertation advisor. I have been most fortunate to have Mark Gultinan as mine. Mark introduced me to cacao, and that has been a relationship among the three of us that I think is unique. I really saw cacao for the first time alongside Mark in a field in St. Lucia. Mark has guided me through this research with his experience, knowledge, inspiration and perseverance. Mark encouraged me to find my way and listen to my voice. In these last months, when I did not know if I could really do this, Mark urged me to not give up. Thank you.

This work was supported in part by the American Cocoa Research Institute Endowed Program in the Molecular Biology of Cocoa, by grants to M.J.G. from the American Cocoa Research Institute and the United States Department of Agriculture Office of International Research Programs, and by support from the Agricultural Experiment Station and the Department of Horticulture of The Pennsylvania State University. I am thankful for that support.

I would also like to thank my friends and colleagues Louise Comas and Ben Belda simply for their friendship over the years and everything they have done to help me in these last weeks when I returned to Penn State. Thank you to Ariadne Comas for taking in a weary traveler.

Frederick Miller and Carrie Miller, my parents, and my wife Janisete Gomes da Silva Miller, have always stood by me and encouraged me to follow my dreams. I owe what I have become to them.

For Janisete...eu te amo...

# CHAPTER 1

## AN INTRODUCTION TO CACAO PROPAGATION

### Overview of Cacao Propagation by Seed

Cacao, *Theobroma cacao* L., has a strong history of seed (seminal) propagation in Central America, where it was first domesticated (Cruz *et al.*, 1995). Seeds from mature fruits are recalcitrant and rapidly lose viability after ripening (Barton, 1965). Nevertheless, seed propagation has been the principal means for the establishment and later for the expansion of production plantings among the more than 50 countries currently growing cacao. Both selected and unselected seminal land race plants account for approximately 95% of cacao trees in production. This is mainly due to the ease of propagation of these plants (Duguma *et al.*, 2001; Hunter, 1990).

Cacao, however, is a heterozygous plant (N'Goran *et al.*, 2000) with a characteristically wide variability for agronomic traits (Figueira and Janick, 1995). Seedlings, while the least expensive option for establishing plantings, are inefficient in cacao production systems. Some of the earliest studies of individual tree yields in productive fields and experimental plots demonstrated that few individual trees propagated from seed (7-20%) produce the majority of the yield measured in dry weight of cocoa beans (seeds from the fruit) ha<sup>-1</sup> (Freeman, 1929; Cheesman and Pound, 1932; Anonymous, 1933, 1934, 1937; Shephard, 1936; Pound, 1945). More recently, Batista (1981) characterized only 23% of a select hybrid cacao variety as highly productive. Helfenberger (1987, *apud* Hunter, 1990) demonstrated the extreme variability in

performance of “highly recommended ‘hybrid’ seed”, in that 80% of dry bean yield resulted from only 20% of the monitored trees. In Ghana, cocoa hybrids of Upper Amazon genetic origin do well in good conditions and badly under poor conditions (Adomako and Adu-Ampomah, 2000), and only from 6.8% to 38.0% of individual trees have yielded more than 10 pods (fruit) year<sup>-1</sup> (Adomako and Adu-Ampomah, 2003). As well, in Puerto Rico, Irizarry and Rivera (1998) tracked production of more than 1,300 trees of select, “uniform hybrid” cacao. The seeds, intended for use as propagules, were distributed to growers worldwide in the 1970s and 1980s. These researchers documented that just 2-3% of seminal trees contributed 60% of the dry bean yield over the first eight years of production. Working in Papua New Guinea (PNG), Efron *et al.* (2003) documented individual tree yield results from the SG2 hybrid that showed high levels of variation in pod yield and very few high yielding trees.

Modern seminal varieties establish well when sown directly in the field or transplanted from nurseries and yield significantly more and earlier than either unselected seedlings or some of the initial releases of selected clonal varieties from germplasm improvement programs (i.e. Trinidad and West Africa, PNG, among others). However, it is clearly established that, even today, most production fields consist of mostly unproductive trees.

Development of “hybrid” seedlings and their distribution to farmers has been, and continues to be, important in obtaining production plants with improved vigor and precocious yield (Glendinning, 1960; Adomako and Adu-Ampomah, 2000). This strategy followed from the prediction that, in the future, there would be a decrease in tree-to-tree variability of seminal trees that was to have resulted from various cacao breeding

programs (Cheesman, 1946a). A second major rationale used to support this strategy to pursue “hybrid” seed propagation relied, in part, on observations of “heterosis” from controlled crosses (Atanda and Toxopeus, 1971). In seed-derived materials, tree-to-tree variation remains significant, general resistance to pests and disease is also mostly unrealized, and a large gap remains between the theoretically estimated potential yields and actual yields in production fields.

### The Importance of Vegetative Propagation for Research and Cacao Production Systems

*“I think that it is now accepted that the future of cacao- perhaps a very distant future yet- is the high yielding clone, the job of the present is to produce it.” - F.J. Pound (1945)*

The development of select, high yielding, and resistant clonal cacao varieties, as well as international cooperative efforts for their distribution and intensive multiplication are considered to be the most appropriate means for realizing improved and sustainable yields (Eskes, 2000; Dias, 2001). For over 80 years, conventional clonal propagation in shade houses and nurseries have been important for establishing germplasm collections, seed gardens, and production of clonal cacao varieties (Wood, 1985). Budding and grafting of select scion material has been an available technology for researchers and innovative growers since late in the 19<sup>th</sup> century. For instance, in 1898, Hart propagated trees by approach grafting. In 1903 Harris demonstrated budding in cacao. Later on, Montserin described the establishment of a large-scale production experiment begun in 1915 by the Trinidad Department of Agriculture, wherein budded seedling were compared with seedling populations from the same trees (Montserin, 1945). Adventitious rooting of semi-hardwood and softwood cuttings gained widespread recognition in

research programs beginning in the early 1930s with extensive investigative work in Trinidad (Pyke, 1932a). Since then, significant genetic gains have been obtained in cacao production systems by various means of conventional cloning of select, high yielding, and pest and disease resistant individuals with desired agronomic characteristics (Jolly, 1956; Esquivel and Soria, 1967).

Selection and development of clones is an arduous and painstaking process, particularly with tropical fruit tree species. Pound screened 50,000 seminal cacao plants for good yield potential and apparent field resistance to witches' broom disease that is caused by the fungal pathogen *Moniliophthora perniciosa* (Cope and Jolly, 1955). One hundred individual seedlings (ortets), selected for evaluation as clones, provided the first Imperial College Selection clones (ICS 1 to 100). Both yield and disease resistance remain difficult traits for selection and breeding, and only a very few of these clones were eventually determined to hold the important suites of traits of agronomic interest. Therefore, the significant genetic gains from the first clonal development program in Trinidad resulted from a selection process wherein only approximately 1 of 10,000 candidates was determined to be a good clone. Observations regarding the utility of clones versus hybrid seminal plants from more recent international efforts for clonal evaluation should take this result into account (Bekele *et al.*, 2003).

Currently once again, in many regions, rehabilitating and replanting fields with genetically improved clonal cacao scions is widely considered the best means of fighting pests and diseases, as well as increasing yields via improved general performance characteristics of newly developed planting materials (Pereira *et al.*, 2000). Mature budding techniques and other topworking methods on old, diseased or otherwise



unproductive trees are popular among growers in Brazil (personal observation) and elsewhere, as well as among researchers (Bahaudin *et al.*, 1984). International research programs and national research centers promote the global exchange of cacao germplasm for use in breeding programs and testing of newly developed clones for later distribution. These programs currently utilize conventional horticultural cloning procedures and lengthy quarantines to safeguard against the spread of pests and diseases between cacao growing regions (Eskes, 2000). The horticultural procedures for collection, transfer, and establishment of materials by the various quarantine programs such as grafting, budding, and rooting of stem cuttings, may inadvertently limit some options for further clonal propagation available to nurseries and growers. In turn, cultural and management practices such as propagation methods, spacing, and pruning among others, may also affect later field performance of clones and unwittingly limit potential gains to improve cacao production if not properly understood and applied.

#### Comparative Field Trials of Seedlings and Rooted Cuttings

Results of a series of field experiments planted at River Estate, Trinidad from 1937-1938 through 1949, known as CRB (completely randomized blocks) 1 to 16, were among the first to provide indications of performance of cloned material in cacao (reviewed in Cope, 1949). Rooted cuttings from several, but not all, experiments were deemed to perform better than budded seedlings. Also in Trinidad, Jolly (1956) compared cocoa from rooted cuttings and seedlings. Cuttings averaged greater dry cocoa bean yields and less variability than seedlings within a period of 3 to 13 years in production. Rooted cuttings produced  $1,004 \text{ lb acre}^{-1} \text{ yr}^{-1}$  compared to  $540 \text{ lb acre}^{-1} \text{ yr}^{-1}$  for seedlings.

A later study consisted of two trials in Trinidad that tracked single-tree yields of clones and hybrid seedlings during the first four years in production (Bartley, 1970). Variability was high and conclusions as to the comparison of rooted cuttings and seedlings were not made. Bartley (1970) suggested that selection from field trials be based “on the combination of several years’ yields after the 8<sup>th</sup> year”.

Dimorphism of Tree Architecture as Related to Conventional Vegetative Propagation,  
Field Management, and Performance

*“The problem is to ensure a constant supply of “hard” chupons of small diameter, which are uncommon under field conditions. This can almost certainly be solved in a budwood nursery by keeping chupon stools of the required scion types hard pruned...” -F.J. Pound (1935)*

Cacao has a characteristic dimorphic growth that affects tree architecture and plays a critically important role in the source material used for vegetative propagation and the consequential architecture of the cloned scion in production. Juvenile orthotropic (upright) growth of the main trunk with spiral phyllotaxy (3/8) contrasts dramatically with plagiotropic (lateral) fan branches with distichous phyllotaxy (1/2) (Brooks and Guard, 1952; Greathouse and Laetsch, 1969; Hallé *et al.*, 1978). It is noteworthy that the great majority of softwood stem materials in the cacao tree canopy generally available in growers’ fields, as well as conventional clonal gardens in propagation nurseries, are plagiotropic fan branches.

The importance of the relative occurrence of these two types of material is significant, because scions and rooted cuttings originating from the two source materials (orthotropic and plagiotropic) exhibit distinct differences in morphology and tree architecture (Harland and Parga, 1924; Cheesman, 1935). Plagiotropic scions, from

lateral canopy branches, develop canopies with unbalanced, spreading habits that require significant attention to heavy formative pruning and/or propping up with supports. Additionally, plagiotropic rooted cuttings more easily succumb to lodging and are susceptible to periods of soil moisture stress during establishment (Jagoret *et al.*, 1992; Lee, 2000; Mooleedhar, 2000). Preliminary investigations of the first established plantings of clones reported that plagiotropic rooted material formed orthogeotropic (or vertical) framework or brace roots (Cheesman 1936, Bowman, 1948). However, Fordham (1973) displayed a diagram in which a plagiotropic rooted cutting of the clone ICS 1 is shown to definitely lack a strongly orthogeotropic framework root system. Characteristics such as susceptibility to lodging and moisture stress in plagiotropic rooted cuttings are likely due to the combination of unbalanced canopy formation and inconsistent development of an orthogeotropic framework root system, which has been documented after exhaustive root system excavations of established production trees (van Himme, 1959; Charrier, 1969; Fordham, 1973). Growers recognize the inconsistency of plagiotropic rooted cuttings to anchor the tree as effectively as seminal material as a serious shortcoming in many producing areas, particularly where hillside plantings are common (Lee, 2000). In contrast, scions and rooted cuttings derived from juvenile orthotropic material develop architecture similar to that of seedlings. Initial orthotropic growth of the scion develops into a vertical trunk, and a jorquette gives rise to a balanced canopy that requires little or no formative pruning (Cheesman, 1935; Efron, 1998). Several studies have shown that orthotropic rooted cuttings root well and form one or more orthogeotropic framework roots (Evans, 1951; Charrier, 1969; Amefia *et al.*, 1985; Bertrand and Dupois, 1992).

The consequences of the dimorphic nature of propagation material (orthotropic vs. plagiotropic) to both shoot and root architecture and their possible impact on plantation management and productivity were of interest during early cacao vegetative propagation efforts (Pyke, 1933a; Cheesman, 1935; Evans, 1951). Cheesman (1945) initiated a series of field studies in Trinidad that separately accounted for the production of both orthotropic and plagiotropic scions as rooted cuttings and grafted seedlings. Cheesman later concluded, referring to production in the plagiotropic versus orthotropic comparison, that “there is no evidence of real difference between the two kinds of material” (Cheesman, 1948).

#### Cultural Methods to Overcome the “Shortcomings” of Plagiotropic Clones

Numerous techniques have been evaluated in an effort to determine the most productive canopy shape pruning management for the unbalanced, bush-like, lateral growth habit of plagiotropic clones (Murray, 1961; Ramadasan *et al.*, 1978). While shape pruning is a straightforward technique for overcoming the unbalanced habit of plagiotropic derived rooted stem cuttings, repeated pruning of wood from established saplings wastes significant carbon resources and places increased demands on labor in the field. As well, excessive pruning has been shown to reduce production (Murray, 1961). Orthotropic scions require only minimal or no shape pruning and consequently place less demand on field labor during sapling establishment.

Current extension advice given to growers in Trinidad recommends that plagiotropic clones should be first established in fields and repeatedly shape pruned over time. Adventitious basal chupons (suckers) should then be promoted to establish a

secondary tree with resulting orthotropic architecture and orthogeotropic framework root system. Afterwards, the initial plagiotropic tree is removed near ground level (Mooleedhar, 2000). This management technique averts the issue of developing productive orthotropic clonal propagation methods while recognizing the inherent advantages of orthotropic clonal cacao both on research station experimental plots and in growers' fields. However, this method wastes significant carbon resources as several years' growth is removed when the plagiotropic tree is replaced by the orthotropic tree. This method also wastes labor and time and fails as an efficient technique to establish a homogeneous stand of orthotropic clones. On a field visit to Trinidad, observation indicated that, even after six years in a well-managed field, the majority of plagiotropic rooted cuttings remain without having developed any chupons. The result is a field planted in an unsatisfactory plagiotropic/orthotropic mosaic (personal observation). Simply stated, it is recommendable to start a field with orthotropic scions if this is the desired end result.

#### Efforts to Promote Orthotropic Scion Material in Stock Plants

Few efforts have been made to establish orthotropic stock plants in clonal gardens for use as scion and/or rooting material. Historically, clones have been propagated exclusively by means of plagiotropic fan material and several expeditions made for collecting wild accessions returned with plagiotropic green wood for grafting (Pound, 1938, 1943). Researchers have widely discredited orthotropic vegetative propagation in cacao during the century following the first account of grafting by that approach (inarched) on seedling stocks by Hart in 1898, patch budding in cacao by Harris and Heyl

about 1903 (Cheesman, 1934), and the seventy-plus year history of rooted cuttings initiated in Trinidad by the thorough work of E.E. Pyke (Pyke, 1932a, 1932b). Reports mention orthotropic material, principally collected as basal chupons, as limited in availability, poor in rooting and/or establishment, and generally discounted it as inappropriate for vegetative propagation (Archibald, 1955; Urquhart, 1961; Cuatrecasas, 1964). Plagiotropic material is the *de facto* material used when vegetative propagation of cacao is considered and reported upon in the literature. Orthotropic material is very rarely mentioned in studies, and is neither distinguished from plagiotropic propagation material, nor utilized in propagation facilities.

However, cultural strategies have been tested in a few instances to promote the growth of orthotropic material in clonal stock plants. This has resulted at best in mixed success. Seedlings have been used at various developmental stages to produce chupons for vegetative propagation (Amefia *et al.*, 1985). Strategies, in which clonal selection followed evaluation at the seedling stage, were made in Togo, West Africa (Cilas *et al.*, 1985), but the promotion of chupons from mature trees produced limited material for rooting in Togo (Cilas *et al.*, 1985; Bertrand and Agbodjan, 1989; Bertrand and Dupois, 1992) as well as in PNG (Efron, 1998). However, seedlings with up to five years in cultivation in greenhouses were demonstrated to produce repeated harvests of chupons when bent to horizontal (Glicenstein *et al.*, 1990). In selection and breeding programs where segregating populations are cloned as early as possible, particularly those foregoing the seedling evaluation stage, orthotropic material is more readily available and may then be more easily introduced into horticultural nursery practices (Efron, 1999; Efron *et al.*, 2000). However, at the time of the current research presented in chapter 2,

the author knew of no other instance where selected clonal material had been used to make entirely orthotropic stock plants or to establish an orthotropic clonal garden.

#### Field Performance of Orthotropic Rooted Cuttings and Grafted/Budded Scions

Orthotropic and plagiotropic treatment comparisons were included in the design of many of the experiments CRB 1 to 16 planted at River Estate, Trinidad (Cheesman, 1940; Cope, 1949). Cope (1949) indicated that the clones tested, particularly those from high yielding clones, did better as rooted cuttings than as budded seedlings. While orthotropic and plagiotropic treatment comparisons were limited by single degree of freedom comparisons, Dodds and Cope (1951) wrote, after several years of preliminary evaluation, that generally “there are no intrinsic differences in the yield potentialities of fan and chupon material”. However, the perceived difficulty in obtaining orthotropic material from a conventional clonal garden was deemed a satisfactory reason for concentrating on the use of plagiotropic material in all later clonal evaluations. Interestingly, current thinking in Trinidad emphasizes the local preference for orthotropic material due to the practical plantation management concerns for reasons mentioned earlier.

Efron (1998, 1999) demonstrated that cultural practices, environment, and genetic components control height of jorquette in orthotropic budded seedlings. Monteverde-Penso *et al.* (2005) suggested, from their findings in Costa Rica and Brazil, that there is the possibility “to find clones with positive and negative GCA (general combining ability) for jorquette and plant height”. In Togo interest in the ability of clones from orthotropic rooted cuttings to form orthogeotropic framework root systems followed from

observations of generally poor adaptation of shallowly rooting plagiotropic cuttings to seasonally dry conditions (Cilas *et al.*, 1985). In that study, unselected juvenile seedlings, after bending, released many orthotropic meristems which promoted large quantities of chupons that were subsequently harvested and used for rooted stem cuttings (Amefia *et al.*, 1985). Glicenstein *et al.* (1990) briefly reported the initial chupon production of two bent, five-year old seedlings for use in *in vitro* axillary meristem culture.

Because of the rarity of orthotropic material in the canopies of mature trees, initial speculation as to the viability of this material for use in production of clones (Pyke, 1933a) has remained unrealized. Consequently, fan branches have been regarded as the only feasible source for production of rooted cuttings of cacao (Baker, 1950). Thirty years after Pyke's pioneering work in propagation, Urquhart (1961) and Cuatrecasas (1964) noted simply that plagiotropic canopy branches adapt to the production of rooted cuttings better than chupons. Presently, germplasm collections, major research stations, and both large-scale and small-scale regional nursery operations rely upon the conventional avenue for clonal cacao scion production via the use of plagiotropic fan branches (de Moraes, 2001).

#### Progress of *In Vitro* Application to Vegetative Propagation

*In vitro* propagation of cacao is a potential tool for germplasm collections and international breeding and distribution programs that has promise to improve clone-based cacao production (Kennedy *et al.*, 1987; Esan, 1992; Dias, 2001). Initial investigations into *in vitro* embryogenesis in cacao utilized non-clonal tissue explants from immature zygotic embryos (Esan, 1977; Pence *et al.*, 1979; Villalobos and Aguilar, 1990). The goal of multiplying select germplasm *in vitro* for acceleration of breeding efforts and



international transfer has focused efforts on cloning cacao under aseptic culture conditions from somatic tissues such as leaves (Litz, 1986), nucellus (Chatelet *et al.*, 1992; Figuera and Janick, 1993, 1995; Sondahl *et al.*, 1993, 1994), and floral explants (Lopez-Baez *et al.*, 1993; Alemanno *et al.*, 1996a, 1996b, 1997). Glicenstein *et al.*, (1990), Esan (1992) and Bertrand (1987) developed micropropagation protocols utilizing vegetative meristems (see Adu-Ampomah *et al.*, 1992 for a review of earlier work in this area). Difficulties with low conversion rates and unresponsiveness of many genotypes to culture conditions limited these aforementioned *in vitro* protocols.

Somatic embryogenesis (SE) in tree species has several applications such as mass clonal propagation, cryopreservation, encapsulation (somatic seeds), liquid culture or bioreactor technology, induction of mutations for crop improvement, and genetic transformation (Jain, 2006). Recent advances in cacao resulted in the development of a more efficient *in vitro* clonal multiplication system for producing large numbers of somatic embryos and SE-derived plants of many genotypes (Li *et al.*, 1998; Maximova *et al.*, 2002). Floral staminodes and petal bases provide the somatic explants for development of primary (1°) SEs via a multicellular organization, while cotyledons from SEs serve as explants for induction of secondary (2°) SEs that have a unicellular origin (Maximova *et al.*, 2002). Additionally, Traore *et al.* (2003) recently developed a micropropagation protocol for multiplying SE plantlets in aseptic culture. The combination of 1°SEs, 2°SEs, and micropropagation allows for the generation of potentially many thousands of SE-derived plantlets to be generated. Additionally, since flowering of cacao stock plants can be maintained throughout the year under controlled greenhouse conditions, this source of propagation material has the added advantage of

being readily available throughout the year both in the greenhouse and under aseptic culture. Thus, somatic embryogenesis protocols are readily adaptable for the efficient and expedient collection and international transfer of select germplasm. Furthermore, the elimination of the disease CSSV (cocoa swollen shoot virus, of the genus *Badnavirus*) has been achieved in cocoa through secondary somatic embryogenesis (Quainoo *et al.*, 2008). This positive result in the phytosanitation of cocoa may play an important role in reducing the need for long quarantines and speed cacao breeding and distribution efforts. Another application of cacao somatic embryogenesis is in the functional study of embryo development (Santos *et al.*, 2005). Furthermore, advances in cryopreservation of somatic embryos may have application for long-term cacao germplasm conservation (Florin *et al.*, 2000; Fang *et al.*, 2004).

Using an *in vitro* protocol to produce SE plants, Fontanel *et al.* (2002) established orthotropic plants in Ecuador and reported on field performance of SE clones from preliminary production tests in that country. Recent observations indicate that SE plants produced via the protocol established by Fontanel and colleagues establish well in the field and demonstrate good early yield (Masseret *et al.* 2005). Lambert *et al.* (2000) established SE field tests in Brazil. Additionally, over 100 different cacao genotypes have been produced by somatic embryogenesis in multiple laboratories (Maximova *et al.*, 2005). Recently, another laboratory in Brazil has produced SE cacao plants using the Pennsylvania State University (PSU) protocol (Silva *et al.*, 2008). As well, field tests of SE-derived plants utilizing the protocol developed at PSU are underway in St. Lucia (Maximova *et al.*, 2008), Ghana, Ivory Coast, Ecuador, and Puerto Rico.

## Complementarity of Biotechnology and Conventional Approaches for Vegetative Propagation

The convergence of conventional and *in vitro* clonal propagation technologies through collaborative research efforts will assist both breeders and growers in obtaining selected, clonal cacao varieties with the desired plant architecture while efficiently utilizing resources. To accomplish this, collection and culture of select germplasm and establishment of initial *in vitro* SE plants should be made in the appropriate laboratory and growth room facilities. Propagation house (for acclimation), greenhouse, and conventional nursery procedures are needed to further multiply the desired clonal material for both research purposes and later distribution to growers.

The efficient utilization of stock plant material is critical when in short supply, therefore budding and grafting offer means of rapidly multiplying limited clone scion material on seedling rootstocks of various ages. While a preliminary experiment in Trinidad investigated the interactions of four clones used as scions and rootstocks in all 16 combinations (Cope and Murray, 1952; Murray and Cope, 1959), no clonal rootstocks with disease resistance or dwarfing characteristics have been developed for cacao (Purdy and Eskes, 2002). As mentioned earlier, rooting of both orthotropic and plagiotropic softwood stem cuttings as planting material was practiced among some of the very first clonal trials for cacao in Trinidad (Pyke, 1933b). Cuttings in these and other trials were mostly of four or more nodes; however, in some instances, single node cuttings were also produced, particularly when starting material was in short supply. Hall (1963) observed that single node cuttings would need more time in the nursery to reach plantable size than larger cuttings. Further, Urquhart (1963) judged that single-node cuttings could be used

to produce three to four times more plants from initial starting material than larger cuttings, and also noted that these were used solely at the “Junta del Cacao” in Trinidad to multiply new or scarce clonal varieties. Therefore, the present study emphasizes rooted stem cuttings of single and few nodes.

## Outlook for Development of Orthotropic Stock Plants and Intensive High Density

### Orthotropic Clonal Gardens

Tissue culture of selected, elite cacao germplasm offers potential advantages over conventional clonal propagation methodology. As well, in circumstances where large resources are available, tissue culture production may allow for vast numbers of clones to be propagated in shorter times than otherwise possible. As tissue culture plants must be transplanted from Magenta vessels, acclimated, and grown to an adequate degree (from four to eight months) prior to field planting, greenhouse and nursery activities inevitably constitute a significant portion of any *in vitro* propagation effort. In circumstances where available resources may need to be allocated in a manner to most efficiently and cost-effectively reach production goals, *in vitro* propagation may need to be complimented with greenhouse and nursery propagation methodology. Once in place, the *ex vitro* propagation system may significantly increase productivity of clonal propagation efforts by increasing the overall numbers of plants produced per unit time. Since nursery propagation involves first the establishment of productive stock plants maintained and arranged in an efficient manner regarding utilization of space, light, and other resources, maintenance of a high-density clonal garden is a prerequisite for nursery propagation. To decrease the time necessary for stock plant production, juvenile, orthotropic material may

be utilized instead of allowing for the stock plant development until phase change, when normally the canopy (plagiotropic material) would be harvested. As indicated above, there is no technological reason not to propagate orthotropic materials (other than their rarity under normal propagation circumstances and difficulty to generate in mature trees), and potentially, there may exist certain advantages that may be gained from the propagation of orthotropic materials.

Experience with somatic embryo derived cacao clones offers the opportunity to investigate the development of an integrated orthotropic clonal propagation system consisting of orthotropic stock plants and rooted cutting methodology. Somatic embryos lend themselves well to this endeavor due to their seminal (seedling-like) growth when acclimated in the greenhouse (Li *et al.*, 1998; Gultinan *et al.*, 2000; Lambert *et al.*, 2000; Maximova *et al.*, 2002; Traore *et al.*, 2003). They may be repeatedly harvested at the softwood stage by strong heading cuts in as little as three months after acclimation. Or they may be left until phase change (jorquette) at the semi-hardwood stage (nine to twelve months in greenhouse), the jorquette fan branches pruned hard, and the trunk bent to horizontal. These procedures release first axillary chupons, and later adventitiously derived chupons formed from the cork cambium. Orthotropic stock plants may be readily established and repeatedly harvested if well managed in the nursery. Both techniques make productive stock plants in addition to being efficient regarding nursery space utilization. Either technique may be appropriate for establishing orthotropic clonal gardens of exclusively orthotropic-producing ortets, and tissue culture does not need to be a necessary step in the process.

Preliminary results from Lambert *et al.* (2000) and Guiltinan *et al.* (2000) indicated that newly acclimated SE plants may be further propagated *ex vitro* under shade in both Bahia, Brazil and under controlled climate greenhouse conditions in temperate latitudes. Single and few node, orthotropic rooted cuttings were successfully produced from orthotropic scion material harvested from acclimated SE-derived plants. More recently the research group at PSU proposed an integrated system for *in vitro* and greenhouse propagation of clonal orthotropic cacao beginning with somatic embryogenesis and incorporating greenhouse production of rooted stem cuttings (Maximova *et al.*, 2005). However, at the outset of this study, it was clear that further investigation was needed to more thoroughly merge conventional orthotropic propagation efforts in the nursery or greenhouse and *in vitro* clonal production avenues to establish firmly efficient and rapid orthotropic clonal cacao propagation from somatic embryos.

### Specific Objectives of the Study

The main objective of this study was towards further technological development and characterization of an integrated *in vitro* and *ex vitro* (greenhouse) vegetative orthotropic propagation system for cacao.

The first goal was to optimize the technical methodology for the establishment and maintenance of high density orthotropic clonal gardens utilizing stock plants from acclimated tissue culture plants at both softwood and semi-hardwood stages. Production of softwood stem cuttings from orthotropic chupons harvested from SE-derived stock plants was monitored during one year. Stem cuttings from both softwood and semi-hardwood stock plants were rooted to determine productive capacities.

The second goal was to investigate the development and physiology of orthotropic rooted stem cuttings from transplant and orthotropic bud breaks through the juvenile softwood and through phase change at the semi-hardwood stage (up to 12 months). Orthotropic plants derived directly from tissue culture, rooting of softwood stem cuttings, and seedlings were characterized and compared under controlled greenhouse conditions.

The third goal was to investigate the development and physiology of the genetically modified cacao line T980603 in comparison to secondary somatic embryo plants from the same genotype in the greenhouse at the juvenile stage.

Detailed technical protocols for many of these methods can be found online at [http://guiltinanlab.cas.psu.edu/Research/Cocoa/tissue\\_culture.htm](http://guiltinanlab.cas.psu.edu/Research/Cocoa/tissue_culture.htm).

## CHAPTER 2

### **GREENHOUSE ESTABLISHMENT OF SOFTWOOD AND BENT SEMI-HARDWOOD ORTHOTROPIC STOCK PLANTS DERIVED FROM SOMATIC EMBRYOGENESIS AND PRODUCTION OF ROOTED STEM CUTTINGS.**

*“In conclusion it must be emphasised that cacao cultivation requires a high degree of horticultural knowledge and skill and should not be lightly undertaken. Nowhere is this need for a high degree of skill more evident than in the technique of vegetative propagation as is demonstrated by the very poor results so often obtained by those with insufficient knowledge.” –R.E.D. Baker (1950)*

#### Introduction

Cacao production (the source of cocoa beans used in chocolate and confectionery) relies predominantly on trees propagated from seed. Seed propagation is inefficient in cacao production systems because the sexually derived tree will segregate for the important agronomic traits of interest to many growers, i.e. precocity, yield, and disease resistance. Clonal propagation of select elite genotypes allows the agronomic traits of interest to be fixed among all the trees in production. This technique promotes a more homogeneous stand where management practices may be uniformly applied. It has been demonstrated that genetic gains have been fixed in several cacao clones through budding, grafting, and rooting of stem cuttings (Jolly, 1956; Esquivel and Soria, 1967).

Early efforts to propagate cacao vegetatively focused on the problems of developing clonal rootstock material, testing the rooting ability of both shoots and roots in closed propagators (without the use of rooting hormone), air layering (marcotting), and mound layering (stooling) (Pyke, 1932b). Both chupon and fan (plagiotropic) stem



cuttings rooted readily from 23 to 24 days from criollo (72%) and forastero (78%) types (Pyke, 1933a, 1933b). There is no mentioning of rooting hormone application in the documentation of these experiments. At six weeks after sticking, Archibald (1954) reported rooting of undetermined material to be 64% in closed frame propagators, as well without rooting hormone.

By the mid 1900s, the method of rooting stem cuttings with the addition of rooting hormones had spread from Trinidad to many cacao growing regions that tested and customized protocols to best suit the local situation. Citing the advantages of rooted cuttings as 1) production of identical clones from parental stock, 2) precociousness, 3) ease of harvest, and 4) improved control of pest and disease by cultural practices, Archibald (1955) utilized the rooting hormone  $\beta$ -indole butyric acid (IBA) at 0.5% in 50% alcohol and quick dip submersion of the cut stem to root both fan and chupon materials. The quick dip with IBA in various concentrations to promote rooting has been preferred by other researchers (McKelvie, 1955, 1956; van Himme, 1960; Odegbaro and Adedipe, 1986; Ramadasan and Ahmad, 1986). However, the convenience of commercially available rooting hormone preparations in talc has been preferred in several other situations with good success often reporting 75% to 85% of rooting (Alvim *et al.*, 1954; Roussel and Couraud, 1968; Ramadasan, 1978).

Large numbers of F<sub>3</sub> Amazon cacao hybrids have been classified as difficult to root, and those attempts at rooting which scored only between 61% and 80% success were classified as “easy rooters” in one test that utilized the quick dip in 0.5% IBA (Odegbaro and Adedipe, 1986). Success in rooting is of particular importance when the material of concern, as many difficult rooters are, is a desirable clone (Ramadasan and

Ahmad, 1986). It is noteworthy that in addition to the genetic constitution of materials that may create variation in success of rooting, environmental effects are also commonly encountered in propagation facilities (Toxopeus, 1970; Flores and Vera B., 1987).

In addition to nursery-based vegetative propagation practices, tissue culture through somatic embryogenesis offers a further means of vegetatively propagating elite plants produced under aseptic, phytosanitary conditions (Li *et al.*, 1998, Maximova *et al.*, 2002). The advantages of propagation by somatic embryogenesis in cacao may best be realized for the advancement of international distribution of disease indexed materials produced under phytosanitary conditions. Aseptic materials will necessitate fewer quarantine restrictions and facilitate international transfer of selected material. However, other applications may be realized in such areas as germplasm conservation, cryo-preservation, development of genetic transformation systems, investigation into the elucidation of plant / pathogen interactions and importantly mass clonal propagation.

After aseptic plant tissue culture through somatic embryogenesis, conventional vegetative propagation may be applied to acclimated plants in an integrated *in vitro* and nursery system (Lambert *et al.*, 2000; Maximova *et al.*, 2008). Mist-house, greenhouse, and nursery propagation practices may best be utilized to bulk up limited *in vitro* materials and produce the clonal plants to be used for establishment in field plantings. Following *in vitro* protocols, greenhouse multiplication entails the acclimation of SE plants, establishment and development of stock plants, protocols for harvesting of vegetative materials, and mass vegetative propagation via implementation of prudent multiplication techniques that efficiently utilize plant materials and resources (Hartmann *et al.*, 1997).

Somatic embryo plants lend themselves well to the development as stock plants. Plants are true to type, disease and pest free and in a juvenile morphological and physiological state (Maximova *et al.*, 2008). Stock plant juvenility is positively correlated with rooting success in the propagation of cuttings taken from them (Hartmann *et al.*, 1997). When maintained under adequate, constant growing environment and good nutrition, properly acclimated cacao somatic embryo plants exhibit vigorous orthotropic (vertical) growth and produce high grade cutting materials throughout the year.

There is a paucity of studies that consistently and systematically examined production of scion material in clonal gardens for use in budding, grafting, and stem cuttings. Very few studies address the production of plant material in clonal gardens and the number of those that focus on the growth of orthotropic material is even more limited. Two studies are worth mentioning with respect to the above. Amefia *et al.* (1985) tested seedlings at various developmental stages to produce chupons for vegetative propagation in Togo. Another important study was carried out by Glicenstein *et al.* (1990) who cultivated seedlings in greenhouses in order to produce repeated harvests of chupons from bent plants.

We have therefore focused in this study on the development of two types of somatic embryo-derived stock plants, softwood and bent semi-hardwood. The first objective of the experiments was to optimize the establishment and maintenance of high density orthotropic clonal gardens utilizing stock plants from acclimated tissue culture plants at both softwood and semi-hardwood stages. Production of softwood stem cuttings from orthotropic chupons harvested from SE-derived stock plants was monitored during one year. Stem cuttings from both softwood and semi-hardwood stock plants were rooted

to determine productive capacities. Softwood chupons (orthotropic shoots) were harvested by periodic light pruning of both softwood stock plants beginning after two months acclimation in the greenhouse, and harvest of semi-hardwood plants beginning after phase change to adult growth at 12 months in the greenhouse. Semi-hardwood stock plants were bent to horizontal and developed chupons along the trunk that were harvested by selective, light pruning. Rooting of stem cuttings is straightforward and inexpensive and allows for large numbers of plants to be propagated in a relatively small space utilizing a limited number of stock plants. Single-leaf rooted cuttings need closer supervision than multiple-node stem cuttings, and while the former may have lower “real efficiency” than the later, single-leaf cuttings have been shown to produce from 3 to 4 times more plants in cacao (Urquhart, 1963). A liquid quick dip with auxin growth regulators  $\alpha$ -naphthaleneacetic acid (NAA), and indole-3-butyric acid (IBA, potassium salt) was used for promoting initiation of adventitious rooting of stem cuttings. The ease of this technique and the quick dip have been shown to produce more and improved consistency in rooting than talc (Evans, 1951; Urquhart, 1963). Intermittent mist and fog were utilized during rooting of stem cuttings harvested from softwood and semi-hardwood stock plants, respectively. After successful rooting, stem cuttings were transplanted to pots and monitored until bud break and determination of propagation efficiency. Both the development of somatic embryo derived stock plants and the successful rooting of stem cuttings established a highly efficient manner to integrate *in vitro* and greenhouse techniques for the vegetative propagation of orthotropic clones that grew true to type.

## Materials and Methods

### *In Vitro Plant Material*

Primary (1°) somatic embryo (SE) plants of the Upper Amazon *T. cacao* spp. *sphaerocarpum* clone Scavina 6 were produced as described previously by Li *et al.* (1998). Subsequent to this research, DNA fingerprinting of these plants indicated that they are not identical to the *bona fide* Scavina 6 tree from the Trinidad germplasm collection, and thus have been redesignated as PSU-Sca 6. The plants were vegetatively propagated and provided to the American Cocoa Research Institute Program in the Molecular Biology of Cacao at The Pennsylvania State University (PSU), University Park, Pennsylvania, U.S.A. by the United States Department of Agriculture (USDA) station in Mayaguez, Puerto Rico.

Immature flower buds were collected in the early morning hours from stock plants maintained in the Department of Horticulture greenhouse at University Park, PA, U.S.A. (42°13'N, 79°51'W) at 222 m above sea level. Collected flower buds were surface sterilized in a sterile solution of 0.06% sodium hypochlorite for 20 min., then rinsed 2 times with sterile water. Floral staminodes and petal bases were dissected and placed onto solid sterile culture media including 2,4-D, thiadizuron and DKW salts. Mature 1°SEs were then converted into plantlets in Magenta vessels for two to three months prior to acclimation in the greenhouse. Induction of secondary embryogenesis and development of 2°SEs followed the method previously described by Maximova *et al.* (2002) and were produced via subculture of 1°SE cotyledon explants. Both types of 1° and 2°SE-derived plants were acclimated to greenhouse conditions. Additionally, a subset of 1°SE and 2°SE-derived *in vitro* plantlets were subjected to micropropagation as described by

Traore *et al.* (2003). During micropropagation, orthotropic shoots were harvested from SE-derived plantlets while still in Magenta vessels. After seven days of root induction on solid media containing IBA, microcuttings were transferred to development media for adventitious root and axillary shoot development. The micropropagation procedure produced two different kinds of plants that were also acclimated to greenhouse conditions, 1) rooted microcuttings (MPC) and 2) stock plants that were harvested multiple times for microcuttings (MPS). Cultures were staged such that all SE-derived plants had three to four leaves and adequate root systems (at least one root with minimum length of 30mm) when transferred to greenhouse acclimation. A detailed protocol manual for the PSU cacao SE procedure can be found online at <http://guiltinanlab.cas.psu.edu/Research/Cocoa/protocols.htm>.

#### *Greenhouse Acclimation and Growing Conditions*

The plantlets grown in the greenhouse included: 1°SE and 2°SE-derived plants and rooted cuttings and stock plants produced via micropropagation of 1°SE and 2°SE-derived plantlets (Figure 2.1). All plantlets were acclimated in a climate-controlled greenhouse with diffuse glazing. They were planted in the dark in tapered cylindrical D-40-Deepots (plastic, 62.5 mm wide by 250 mm deep, Hummert, Earth City, MO, U.S.A.) in coarse round grain silica sand (Grade 13, U.S. Silica, Ottawa, IL, U.S.A.) and spaced at 0.20 m distance from center or 0.22 m<sup>2</sup> bench top per plant. Drip irrigation was supplied for 3 minutes until freely draining from bottom of pot eight times per day with a 1:10 dilution of modified complete nutrient solution at 150 µM N, pH 6.5 (Hoagland and Arnon, 1950). During the first week, plants received intermittent fog (10 seconds every 15 minutes).

Figure 2.1. Flow diagram from *in vitro* plantlets through *ex vitro* softwood and bent semi-hardwood stock plants to rooted cutting production.

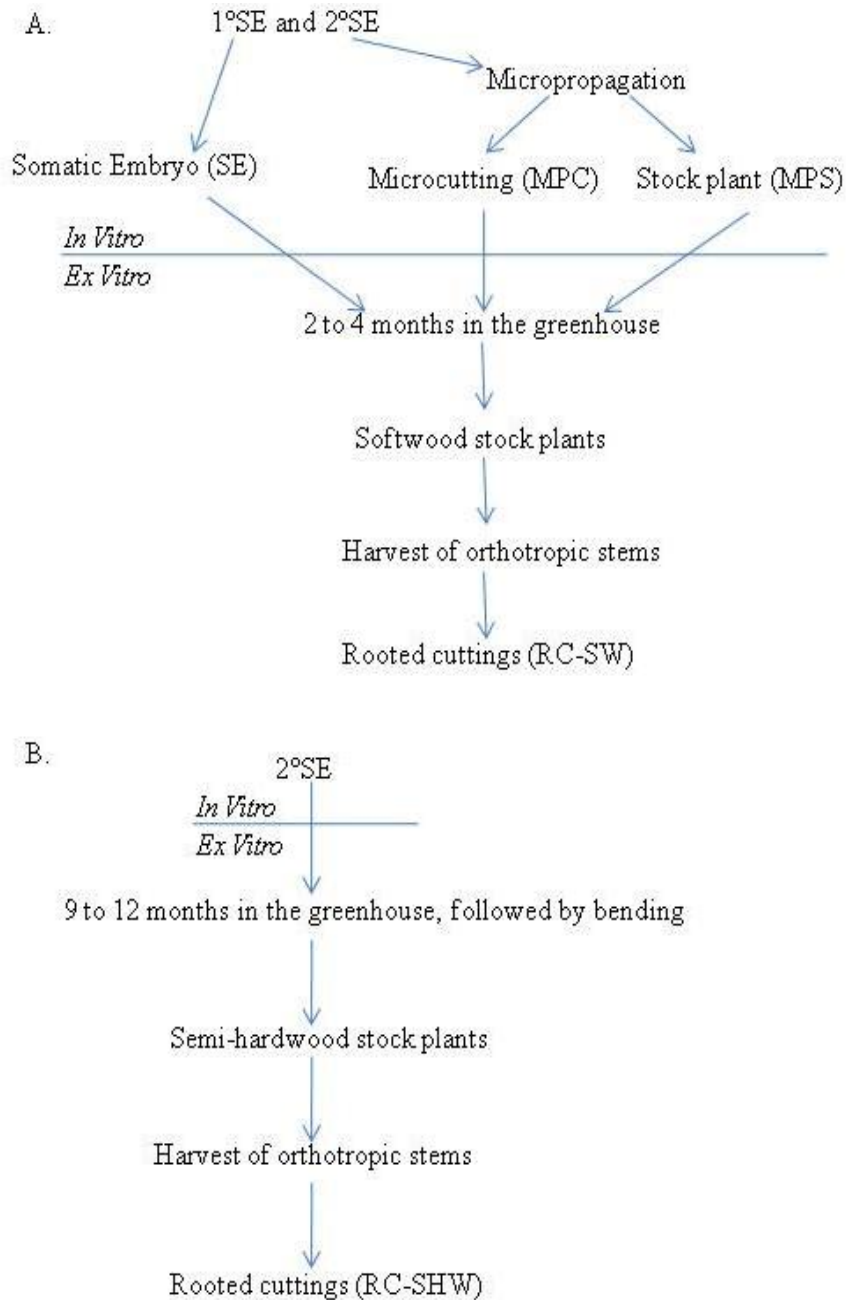

Flow diagram depicts the production of the various SE plants produced *in vitro*, via  $1^{\circ}\text{SE}$ ,  $2^{\circ}\text{SE}$ , and micropropagation. Plantlets were removed from *in vitro* Magenta vessels, acclimated *ex vitro* in the greenhouse, and developed into stock plants. Orthotropic stem materials (chupons) were harvested from stock plants to produce rooted cuttings. A. depicts orthotropic stem cutting production from softwood stock plants. The utilization of micropropagation for both  $1^{\circ}\text{SE}$  and  $2^{\circ}\text{SE}$  was done prior to *ex vitro* acclimation. B. depicts orthotropic rooted stem cutting production from bent semi-hardwood stock plants.  $2^{\circ}\text{SE}$  plants were grown in the greenhouse for up to 1 year, then bent to produce orthotropic stems (chupons) that were harvested from stock plants and used for stem cuttings.

Plants were grown under diffuse sunlight and constant shade ( $\leq 200 \mu\text{mol}\cdot\text{m}^{-2}\cdot\text{sec}^{-1}$  PAR) for four weeks with limited air movement. After four weeks, plants were grown under diffuse sunlight, overhead shade (during high light intensity), and with supplemental light (during low light intensity). Day length was 14/10 hour light/dark. Combined use of automatic shade curtains and high pressure sodium lamps was utilized to maintain light levels between 400 to 1000  $\mu\text{mol}\cdot\text{m}^{-2}\cdot\text{sec}^{-1}$  PAR at canopy level during light hours. Lights (430 Watt high pressure sodium lamps) were suspended above the bench on center, distributed every 2 m, and maintained at approximately 1.5 m above the canopy. Automatic overhead shade curtains and vertical blackout curtain (west side) were maintained closed during dark periods. Temperature and relative humidity were maintained at 28°/25° C during day/night, respectively, and RH at 75%.

#### *Softwood Stock Plant Development and Rooting of Cuttings*

After a two month greenhouse acclimation and establishment period, orthotropic shoots longer than 0.15 m were harvested by strong heading cuts leaving three to four nodes on the stock plant with leaves of lamina length of 80 mm or longer. Cuttings with stem diameters less than approximately 4 mm were found to be inadequate for rooting, therefore shoots were allowed to flush until stem diameter, at 40 – 60 mm distance basipetally from the shoot apex was  $\geq 4$  mm. All shoots were taken at the interflush I-2 stage of the cyclic leaf production cycle (flush) as described by Greathouse *et al.* (1971), with apical meristems “temporarily dormant” and leaves from the most recent flush fully expanded and hardened. Each orthotropic shoot was allowed to flush from two to four times prior to harvesting. At harvest, one to four shoots were harvested per stock plant. Successive harvests, consisting of orthotropic shoots from 0.20 to 0.40 m length, were



made such that two nodes above the previous harvest cut remained on the stock plant. The frequency of harvests was determined by stock plant vigor and shoot morphological characteristics, and these were limited, during any of the weekly harvests, to taking a maximum of four orthotropic shoots taken per stock plant. Multiple orthotropic axillary meristems on stock plants swelled under the fresh cut during the first week following orthotropic shoot harvest, and axillary bud break usually occurred by seven to ten days after harvest.

Softwood cuttings of 40 – 60 mm in length and mostly with two leaf nodes were made from the entire harvested orthotropic shoot. Node number varied from one to seven and did not affect rooting success. The bottom 20 mm of each cutting was trimmed of leaves at the petiole base. A maximum of four leaves per cutting remained. The leaf laminae were trimmed to 60 mm length.

Three concentrations (2, 4, and 8 g·L<sup>-1</sup>) of a synthetic auxin solution of equal parts (1:1) of  $\alpha$ -naphthaleneacetic acid (NAA), and indole-3-butyric acid (IBA, potassium salt) in 50% ethanol were used for quick dip (five seconds) adventitious root induction. Previous investigators have shown this method to be effective for rooting of softwood cuttings for cacao propagation (Evans, 1951; Urquhart, 1963). Cuttings were quickly dipped in auxin and immediately struck 20 to 30 mm deep in steam-sterilized, coarse silica sand-filled preformed trays that were thoroughly wetted just prior to sticking. To limit shading from leaf overlap, the density was established at 80 cuttings m<sup>-2</sup> in 50 mm diameter by 90 mm deep cavities with adequate substratum drainage provided by thin polyester batting fabric overlaying a perforated platform. Cuttings were rooted under moderate shade (100 – 400  $\mu\text{mol}\cdot\text{m}^{-2}\cdot\text{sec}^{-1}$  PAR), intermittent mist (10 sec every 10 - 15

minutes) to maintain 100% RH, and irrigated overhead with distilled-deionized water every two to three days beginning on day two after sticking. After four to five weeks, cuttings were scored for rooting by noting presence/absence and number of adventitious roots.

Following successful rooting, stem cuttings were transplanted into coarse sterilized sand-filled D-40-D pots or 7.65L tree pots (0.2 m X 0.2 m X 0.32 m, Stewie and Sons, Inc, Tangent, OR, U.S.A.) and placed under the same growing conditions as softwood stock plants without a hardening period. Plants were maintained through bud break.

#### *Semi-Hardwood Stock Plant Development and Rooting of Cuttings*

Secondary SE plants were acclimated and established under greenhouse conditions as described earlier. At two months in the greenhouse, plants were transplanted to 40-liter cylindrical pots in coarse silica sand until jorquette development, approximately 9 - 12 months post-acclimation. All plagiotropic branches were pruned (tipped) just above the jorquette, and the trunk of each sapling was then bent over and positioned to near ground level over the course of two weeks. Bending of juvenile trees served to stimulate axillary orthotropic bud break and the production of orthotropic chupons. The trunk remained in this final bent-to-horizontal position for the remainder of the experiment. Plants were grown at a density of 1.7 plants m<sup>-2</sup> in two rows with 1.5 m distance between rows and 0.60 m staggered spacing between plants. Trunks were bent inwardly between the two opposing rows in an “interdigitated” manner, resulting in 0.30 m base of trunk to jorquette spacing between plants from alternating rows. Five newly bent plants and five that were previously bent for one year in a preliminary experiment

were harvested for chupons and data collection. Chupons between 0.40 m to 1.0 m in length were harvested after two months, and subsequent harvests were made at two-week intervals.

Leaf laminae were trimmed from harvested chupons to 100 mm, and single leaf (single node) stem cuttings of 30 to 40 mm were made. The cuttings were numbered by position beginning from the shoot apex (position 1) and increasing basipetally towards the base of the harvested orthotropic chupon. Distance of harvested chupon from base of trunk was noted. Cuttings were then quickly dipped in auxin (1:1 NAA:IBA), struck, and maintained for adventitious rooting according to the protocol described above, except for the substitution of mist by intermittent fog. After four to five weeks, adventitious roots were counted on each cutting. Rooted stem cuttings were transplanted into coarse sterilized sand-filled D-40-Deepots, 7.65L tree pots or maintained in cells of preformed plant trays for four weeks for determination of bud break under the same growing conditions as described above for softwood stock plants.

#### *Experimental Design and Analysis*

Softwood stock plant production and rooting efficiency (% rooting) were analyzed as 2 X 3 and 2 X 3 X 3 factorials, respectively. Factor A consisted of two levels of SE types (1° and 2°), and factor B differentiated among the three levels of *in vitro* multiplication methods (micropropagated cuttings [MPC]; micropropagated stock plants [MPS]; and those plants without *in vitro* multiplication [SE]). Analysis of rooting efficiency also included Factor C, having three levels of auxin concentration (2, 4, and 8 g·L<sup>-1</sup>). All 90 stock plants were placed on one greenhouse bench in a completely randomized arrangement of treatments with 15 repetitions per treatment. Bud break and

establishment was scored on from 40 to 60 rooted cuttings of each of the 18 treatment combinations for rooting efficiency.

Semi-hardwood stock plant production and rooting efficiency of single-node cuttings were made with completely randomized arrangement of treatment combinations in a 2 X 3 factorial consisting of factor A, stock plant age (one and two years in greenhouse); and factor B, auxin concentration (2, 4, and 8 g·L<sup>-1</sup>). Rooting experiments were repeated once. Regression analysis was used to describe the optimal length of time of rooting cuttings from softwood stock plants. Bud break and establishment was scored for 80 to 150 rooted cuttings for each of the six treatment combinations and rooting efficiency was calculated.

The software package SPSS version 10.1 for Windows (SPSS Inc., Chicago, IL, U.S.A.) was used for all statistical analyses.

## Results

### *Production of Orthotropic Stock Plants in Two High-Density Somatic Embryo Derived Experimental Clonal Gardens*

Two different orthotropic rooted cutting propagation methods were developed in separate experiments using SE-derived stock plants. The stock plants were both derived from various tissue culture processes and also maintained under contrasting stock plant husbandry methods. Figure 2.2 and Figure 2.3 demonstrate some of the main processes that were developed through the two independent experiments and protocols for developing softwood and semi-hardwood orthotropic SE-derived stock plants and rooted cuttings. The productivity of softwood orthotropic shoot material (chupons) and rooting

Figure 2.2. Softwood SE-derived stock plant development and production of softwood orthotropic rooted stem cuttings.



Softwood stock plants and rooted stem cuttings: a) close-up of an individual plant nearly ready for first harvest of orthotropic shoots at two months after acclimation and greenhouse growth, notice plant has two orthotropic shoots prior to first harvest (arrows); b) bench top with 90 softwood plants; c) stock plant after ten months and four previous harvests, note three shoots ready for harvest (arrows); d & e) recently harvested ten-month plants with new shoot development (arrows) seven and ten days after harvest, respectively; f) cuttings in rooting containers; g) one, two and three-leaf rooted cuttings (RC-SW) 28 days after sticking; h) rooted cuttings (RC-SW) four months after transplanting.

Figure 2.3. Semi-hardwood stock plant development and production of softwood orthotropic rooted stem cuttings.



Set-up of bent, semi-hardwood stock plants and rooted cuttings: a) stock plants ready for harvest of chupons in two rows with trunks bent in 'interdigitated' fashion towards the center; b) overhead view of bent stock plants showing intensive chupon production; c) bent stock plant ready for harvest; d) same bent stock plant approximately ten days after harvest showing regrowth; e) close-up of bend (photo d at arrow) showing previously harvested axillary chupon cut (white) and new adventitious chupon growth; f) single-leaf (node) rooted stem cuttings (RC-SHW) 28 days after sticking; g); rooted cuttings (RC-SHW) four months after transplanting.



efficiencies of orthotropic softwood stem cuttings from various sources of softwood and bent semi-hardwood SE-derived stock plants were determined during one year.

### *Softwood Stock Plant Development*

Softwood SE stock plants were produced by six *in vitro* protocol treatment combinations. These consisted of two somatic embryogenesis methods, primary (1°SE) and secondary (2°SE), for each of the following 1) those that underwent no post conversion *in vitro* multiplication (SE), 2) cuttings from micropropagation (MPC), and 3) stock plants from micropropagation (MPS). Primary SEs were regenerated from cultured floral staminode and petal explants and primarily have multi-cellular origin. Secondary SEs were regenerated from 1°SE cotyledon explants and were demonstrated to have primarily a single-cell origin (Maximova *et al.*, 2002). All cacao plants from 1°SE and 2°SE, as well as those produced by micropropagation, had orthotropic, juvenile growth and spiral phyllotaxy characteristic of juvenile phase of seedling development.

An individual softwood stock plant, two months after acclimation and greenhouse growth, is shown in Figure 2.2-a. Figure 2.2-b shows the layout of plants on the growing bench at the same stage two months after acclimation. At this stage, the plants have produced three to four abbreviated but rapid growth flushes of one to four leaves each. Figure 2.2-c shows an established stock plant at ten months in the greenhouse. This plant had previously been harvested four times and was ready for further harvesting of orthotropic shoots. Figure 2.2-d and 2.2-e show a similar stock plant at seven and ten days after orthotropic shoot harvest, respectively, and illustrate the immediate and prolific axillary bud break and shoot development in stock plants that follows chupon harvest.

Two months after acclimation in the greenhouse, softwood stock plants were first harvested for softwood orthotropic shoots (Figure 2.2-a). From the first one or two orthotropic shoots, 2.4 (1°MPS) to 5.1 (1°SE) stem cuttings were taken by the end of month four from among all six treatment combinations of softwood stock plants (Table 2.1). Chupon productivity increased rapidly during the first eight months during a period of initial stock plant establishment, and increased more gradually between months nine and twelve. Stem cutting production leveled off at approximately 20 stem cuttings (one to seven nodes) per stock plant per two-month period. Small but statistically significant differences were observed for the production of stem cuttings for the two main effects of SE type (1° versus 2°,  $p = 0.01$ ) and the *in vitro* propagation method (SE, MPC, MPS,  $p = 0.01$ ). Primary SE stock plants produced a combined average of 12.9 rooted cuttings, while 2°SE stock plants produced 15.3 rooted cuttings during each two-month period. As well, SE, MPC, and MPS stock plants (combined 1° and 2° means) produced 14.7, 12.6, and 14.9 rooted cuttings respectively, per two-month period. Table 2.1 (bottom row) shows the means for total stem cuttings taken per stock plant over the year of harvests. MPC were the poorest stock plants among both 1°SE and 2°SE, and pair-wise comparisons demonstrate that MPC stock plants produced significantly fewer rooted cuttings than SE and MPS stock plants ( $p = 0.05$ ).



Table 2.1. Production of orthotropic softwood stem cuttings from softwood stock plants.

Month	1°			2°		
	SE	MPC	MPS	SE	MPC	MPS
3-4	2.9 ± 1.0	2.6 ± 0.6	2.4 ± 0.6	5.1 ± 1.3	3.3 ± 0.6	2.7 ± 1.0
5-6	7.6 ± 1.4	7.1 ± 1.6	9.9 ± 1.5	7.5 ± 1.2	7.1 ± 1.4	7.9 ± 1.8
7-8	16.8 ± 2.0	12.1 ± 1.7	17.9 ± 2.1	20.9 ± 2.3	17.9 ± 2.8	20.1 ± 2.0
9-10	19.1 ± 1.3	17.6 ± 1.8	22.0 ± 1.1	24.8 ± 1.6	23.1 ± 1.5	23.3 ± 1.4
11-12	20.1 ± 1.4	16.0 ± 1.1	21.2 ± 1.5	23.7 ± 1.2	21.0 ± 1.8	22.7 ± 2.2
1 year	65.2 ± 3.3bc	54.3 ± 4.0c	71.9 ± 3.2ab	80.5 ± 3.6a	70.6 ± 5.1ab	75.3 ± 3.8ab

Production of orthotropic softwood stem cuttings beginning after 2 months acclimation and growth in greenhouse for six treatment combinations of primary (1°) and secondary (2°) somatic embryo stock plants. Plants received no *in vitro* micropropagation (SE); were micro-propagated (MPC); or were micropropagation stock plants (MPS). Each value represents the mean number of rooted cuttings harvested per stock plant during a two month period. Each is mean of 15 repetitions (± standard error of the mean). One year totals (bottom row) were analyzed by ANOVA, and means separated by studentized LSD; means followed by the same letter are not significantly different according to ANOVA post hoc test ( $p \leq 0.05$ ).

While Figure 2.2-d and 2.2-e show a stock plant soon after all well-developed orthotropic shoots were harvested, orthotropic shoot development was many times asynchronous. Chupon harvest was frequently staggered on a plant to allow for further development of less well developed internal chupons. The hedge-like bench of 90 stock plants, as a whole, yielded cuttings for rooting on a weekly basis at the rate of over 25 stem cuttings m<sup>-2</sup> bench top throughout the experiment.

#### *Rooting of Cuttings from Softwood Stock Plants*

The set-up during rooting of cuttings under mist in sand-filled preformed trays is shown in Figure 2.2-f. Successful rooting of single and multiple node cuttings from softwood stock plants was obtained at all three auxin concentrations (Figure 2.2-g). Table 2.2 shows the rooting efficiency of softwood cuttings from both softwood and semi-hardwood stock plants at four weeks after sticking. Simple effects for both factors A

(1°SE and 2°SE) and B (micropropagation steps- SE, MPC, and MPS) were non-significant; therefore, these were pooled. Pair-wise comparisons of auxin concentrations show that rooting efficiency at four weeks after sticking was lower for 2 g·L<sup>-1</sup> (73%) than for 4 and 8 g·L<sup>-1</sup> (90% and 89%, respectively) for softwood stock plants at  $p = 0.01$  (Table 2.1). Number of roots per cutting (Table 2.2) ranged from three to four for 2 and 4 g·L<sup>-1</sup>, respectively, and were significantly fewer than eight roots per cutting for the 8 g·L<sup>-1</sup> auxin concentration ( $p = 0.05$ ).

Table 2.2. Adventitious rooting of softwood orthotropic (chupon) stem cuttings from softwood and bent semi-hardwood stock plant types.

Auxin Conc.	Softwood		Bent Semi-hardwood	
	Rooting %	# Roots	Rooting %	# Roots
2	73 ± 3a	3.5 ± 0.2a	70 ± 4a	3.7 ± 0.2a
4	90 ± 2b	4.3 ± 0.2a	75 ± 3a	5.7 ± 0.3ab
8	89 ± 2b	8.3 ± 0.5b	76 ± 3a	9.1 ± 0.4b

Percent of cuttings successfully rooted (% rooted) and mean number of adventitious roots produced per successfully rooted cutting (# Roots) after four weeks from two separate sets of experiments testing softwood orthotropic material from softwood and bent semi-hardwood stock plants. Cuttings were rooted under three auxin concentrations (2, 4, 8 g IBA·L<sup>-1</sup>). Values represent mean (± standard error of the mean) for 18 and 15 repetitions, for softwood and semi-hardwood stock plants, respectively. Each repetition consisted of between 12 to 50 individual rooted cuttings. Values in the same column followed by the same letter are not significantly different according to ANOVA post hoc test ( $p \leq 0.05$ ).

All softwood cuttings from softwood stock plants produced orthogeotropic (growing vertically downwards or nearly so) adventitious roots (Figure 2.2-g). This is in contrast with plagiotropic material that produces adventitious roots of varying orientations (Pyke, 1933b; Charrier, 1969). By transplanting, at four to five weeks after sticking, many roots had reached the bottom of the media container (Figure 2.2-g arrow), which confounded root length measurements (data not shown).

A time trial was conducted to investigate the optimal length of time for rooting material at  $4 \text{ g}\cdot\text{L}^{-1}$  auxin (Figure 2.4). This time trial was conducted over three months and consisted of sample sizes ranging from 19 to 220 rooted cuttings for each length of time (from 11 to 38 days) rooting under intermittent mist. Figure 2.4 shows that, by four to five weeks after sticking, over 85%, and in some cases nearly 100%, of cuttings had rooted.

Figure 2.4. Adventitious rooting success over time of stem cuttings from softwood stock plants.

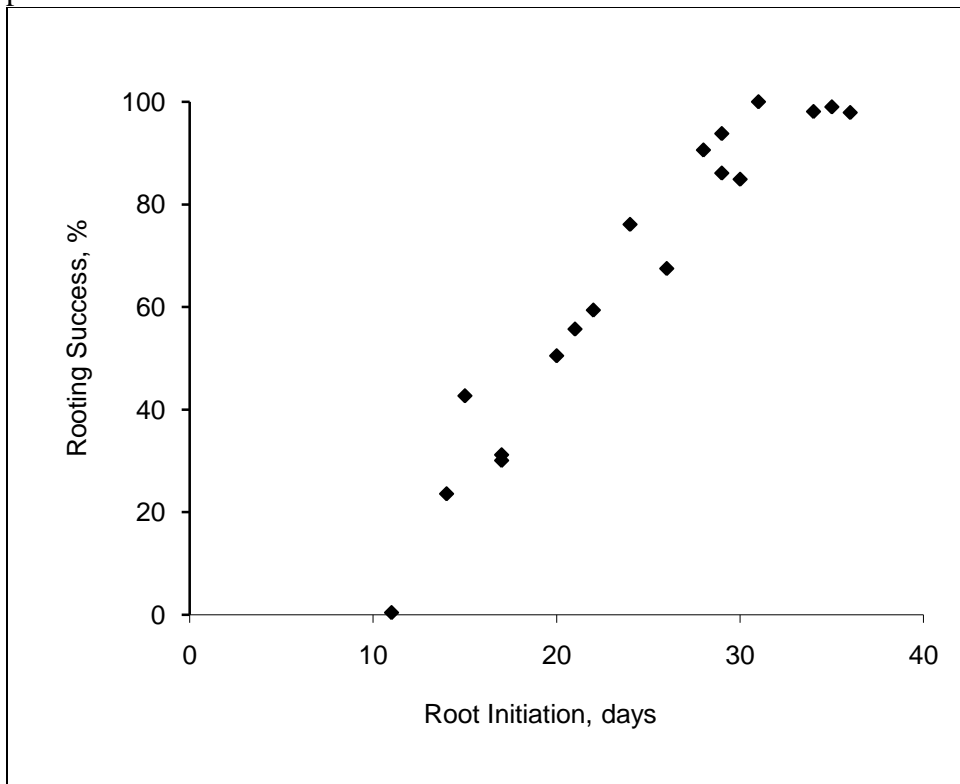

Adventitious rooting percentage over time of cuttings taken from softwood stock plants. Each point represents the percent rooted of between 19 – 220 cuttings struck.

### *Semi-Hardwood Stock Plant Development*

Semi-hardwood stock plants were derived from bent secondary embryo-derived plantlets (2°SE) as described earlier. Both newly bent, semi-hardwood plants (nine months to one year in the greenhouse) and those previously bent from a preliminary experiment (two years in the greenhouse) were used. Strong heading cuts of the first plagiotropic branches at the jorquette, combined with bending-to-horizontal of trunks, stimulated release of axillary and adventitious orthotropic meristems and resulted in prolific and sustained chupon production along the upper side of trunks.

The production of chupons from semi-hardwood stock plants is shown in Figure 2.3-a through 2.3-f. Figure 2.3-a demonstrates from a side view of the “interdigitated” layout of the plants and hedge-like appearance of the chupon-producing stock plants, while Figure 2.3-b shows the same plants from an overhead view. Figure 2.3-c shows a single plant ready for early harvest of small chupons, while Figure 2.3-d shows a previously harvested bent semi-hardwood stock plant at approximately ten days after complete harvest of all chupons. After harvest, axillary meristems swelled, broke and developed into chupons on the upper surface (under tension) and also rarely along the sides of the trunk, while meristems on the lower surface (under compression) remained dormant. The succession of flushes was rapid, and chupon production occurred along the length of the bent trunk (Figure 2.3-c). Chupon development was generally most vigorous just above the base of the trunk and along the strongly bent portion above the base of the trunk and less so proximate to the jorquette. Axillary meristems at the base of harvested chupons developed into chupons for later harvests when the most basal nodes were left during harvesting. As well, when the harvest cut was made below the most basal node,

adventitious meristem development occurred in instances at the cut surface along the cork cambium as well as that shown in Figure 2.3-e (arrows) on the main trunk at the chupon branching juncture. While Figure 2.3-d shows a plant ten days after complete harvest of all chupons, staggered harvests on individual stock plants of only fully developed chupons were also commonly made. A large chupon with trimmed leaves ready for making stem cuttings is shown in Figure 2.5.

Figure 2.5. Orthotropic chupon from bent semi-hardwood stock plant.

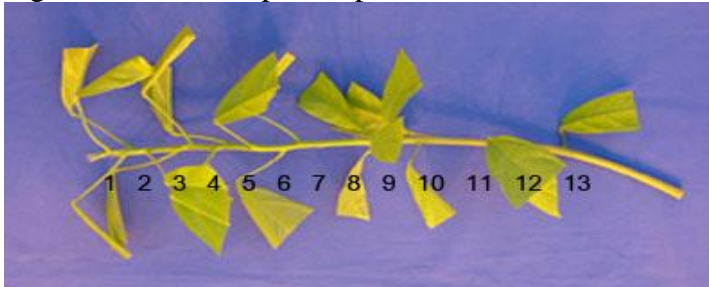

Harvested chupon for stem cuttings with leaf laminae trimmed to 100 mm. Position (node) of stem cuttings is indicated from apex (position 1) and sequentially towards the base of chupon.

Production of chupons from bent semi-hardwood SE stock plants over time is shown in Table 2.3. Previously bent stock plants were harvested immediately and produced material for 26 cuttings per month or 310 cuttings per year. Newly bent plants had a delay of four months prior to the first harvest to allow initial axillary meristem release and three to four growth flushes. These newly bent stock plants produced 260 cuttings during the first year after bending and reached an average production of 35 cuttings per month, or over 400 per year. Larger chupons (0.40 – 1.0 m long) were harvested less frequently (every two to four weeks) from bent semi-hardwood 2°SE stock plants as compared with softwood 1°SE and 2°SE stock plants. Production peaks at nine to ten months (Table 2.3, Harvest Period 5) coincided with extended day length during

the northern hemisphere summer. All semi-hardwood stock plants remained vegetative throughout the experiment, and only a single stock plant had developed flowers after an additional year of observation (four years in the greenhouse). Similarly bent SE-derived stock plants were maintained planted in the ground within a shade house in St. Lucia, BWI since mid-2000, and these plants continued to produce many orthotropic chupons for more than 5 years (M. Guiltinan, personal communication).

Table 2.3. Production of single and few node softwood stem cuttings from bent semi-hardwood stock plants.

Harvest Period	Newly Bent	Previously Bent
1	-	40 ± 6
2	-	47 ± 5
3	44 ± 3	50 ± 5
4	60 ± 4	55 ± 6
5	81 ± 5	65 ± 5
6	68 ± 4	57 ± 8
7	68 ± 9	58 ± 9
Mean	64 ± 3	53 ± 8

Stem cutting production during 7 two-month harvest periods and mean two-month production. Rooted cuttings were made from harvested orthotropic chupons from two types of bent stock plants; newly bent, and previously bent. Each value represents the mean of five repetitions (n=5) ± standard error of the mean.

#### *Rooting of Cuttings from Semi-Hardwood Stock Plants*

Figure 2.3-f shows two rooted stem cuttings from chupons harvested from semi-hardwood stock plants. Stem cuttings from semi-hardwood stock plants had rooting efficiencies from 70%–76%, including all three auxin concentrations (Table 2.2). No significant differences in percentage of cuttings that successfully rooted were observed among the three auxin treatments. Number of roots per cutting, however, was significantly and positively correlated with auxin concentration; means ranged from 3.7, 5.7 and 9.1 roots per cutting for 2, 4, and 8 g·L<sup>-1</sup> auxin, respectively (Table 2.2). Stem

cuttings from newly bent and previously bent plants rooted equally well. Similarly, no differences were noted in rooting efficiency of stem cuttings taken from chupons at different harvest positions along the trunk of the bent stock plant (from the base of the trunk to jorquette) nor from stem cuttings taken at different positions (nodes) along the chupon (see Figure 2.5).

#### *Transplant and Establishment of Cuttings*

Bud break and establishment upon transplant (without hardening stage) was 97% and 90% successful in rooted cuttings of softwood and semi-hardwood stock plants, respectively. Rooted cuttings from softwood in Figure 2.2-h and semi-hardwood stock plants in Figure 2.3-g are shown at five months after root initiation (four months after transplant). Propagation efficiency, or the percentage of plants produced per cutting made, ranged from 66% to 81% from softwood stock plants and from 68% to 74% from semi-hardwood stock plants. Plants produced using these methods have been successfully transplanted to a field test in Puerto Rico (M. Guiltinan, unpublished data).

### Discussion

#### *Previous Results with Orthotropic Rooted Cuttings from SE Derived Softwood Stock*

##### *Plants*

The direct multiplication of orthotropic material from proven cacao clones has previously required sophisticated *in vitro* methods (reviewed in Maximova *et al.*, 2002) or elaborate, conventional measures (discussed in Bertrand and Dupois, 1992). To the best of the author's knowledge, Lambert *et al.* (2000) were the first to report the rooting of orthotropic cuttings from newly acclimated softwood SE stock plants. While this study

represented a significant achievement in the nursery stage of orthotropic multiplication of SE-derived clones, further investigation into the topic was necessary. For example, Lambert and colleagues did not mention the production values of cuttings from these stock plants. Rooting efficiencies of cuttings do appear similar for softwood stem cuttings from softwood stock plants between the current study and the work of Lambert and colleagues. However, significant differences in horticultural practices regarding both the development of stock plants and protocols for rooting and hardening of cuttings may be noticed.

The first noteworthy contrast between the current study and that of the Lambert *et al.* (2000) study is that laboratory and greenhouse production facilities, as well as technical staff and clones used, differed according to where acclimation, rooting, hardening and other activities were performed. While in the current study all *ex vitro* activities were carried out in a climate controlled greenhouse, the earlier study used a shade house out of doors. Additionally, in the present study explants were harvested from plants maintained in the same climate-controlled greenhouse under the same conditions as mentioned earlier for the softwood stock plants, in contrast with Lambert and colleagues who collected floral explants from unspecified field-raised clones.

The liquid quick dip at 2, 4, and 8 g·L<sup>-1</sup> of αNAA and IBA 1:1 in 50% ethanol utilized in the present study contrasted with the use of rooting hormone (4 g·kg<sup>-1</sup> IBA in powder talc) by Lambert and colleagues. Figure 2.4 demonstrates that optimal rooting required four to five weeks in the present study, while negligible incidence of rotting occurred even at six weeks under fine mist. Lambert and colleagues also reported that the time for rooting under coarse mist in excess of three weeks was positively correlated with



stem rotting, cutting mortality, and poor bud break. In the current study, transplanted cuttings were placed directly in the same growing conditions along with stock plants without hardening processes common for tropical hardwood plants. This resulted in 97% survival during bud break. As well, Lambert and colleagues used a three-step acclimation and hardening protocol that included returning flushing cuttings back to a mist room with a protective plastic covering (personal observation). In the current study, SE plants were harvested as early as two months following acclimation with no stock plant mortality while Lambert *et al.* (2000) further reported a loss of 11% of softwood SE stock plants upon the first harvest of orthotropic shoots four months after acclimation. Varied responsiveness of the different clones used in the two studies may not be disregarded as a potential factor to explain the differences in initial stock plant mortality. However, this seems an inadequate explanation in the present case. The more likely explanation is that these differences may have arisen from improved environmental controls in the climate controlled greenhouse and differences in horticultural practices between the studies. These improvements to stock plant management would result in more vigorous stock plants as well as decreased shock to the plants when harvested for rooting material.

*Previous Results with Orthotropic Cloning of Non-SE-Derived Semi-Hardwood Plants*

In the current study, rooting efficiency ranged from 70% to 76% for stem cuttings taken from chupons from bent semi-hardwood stock plants. Rooting efficiency was also independent of chupon position along the stock plant trunk and position of the cutting along the chupon (data not shown). Use of unselected, bent semi-hardwood seedlings as orthotropic clonal material was reported from Togo by Amefia *et al.* (1985). That study showed a production per plant of 8.4 orthotropic axes (chupons) and 14 rooted cuttings

from a single harvest. Rooting efficiency ranged from 62% to 95%. Rooting efficiency was higher for stem cuttings taken from chupons growing proximate to the base of the trunk and lower for those taken from chupons harvested proximate the jorquette. The efficacy of the procedure for establishing stock plants was left in doubt as no further production of orthotropic axes was reported (Amefia *et al.*, 1985). Bertrand and Agbodjan (1989) examined “arching” of juvenile seedlings in attempts to generate proliferation of chupons for use as further clonal material. The method produced only 13.4 cuttings per stock plant after five months with high rates of variation among the “arched” plants. This result may be due in part to the severe apparent toppling of the main trunk at ground level (Bertrand and Agbodjan, 1989) versus the bending used in the present study.

Both single node and few node stem cuttings were made in the current study, and reached a production of 310 and 400 cuttings per plant per year in two different replicates, however, the number of buds (axillary meristems) was not counted which limits a direct comparison between studies. Glicenstein *et al.* (1990) reported the production of two bent, five year old seedlings for chupon harvest used in axillary meristem *in vitro* propagation (Flynn *et al.*, 1990). The first harvest made after two months produced 14 and 26 shoots of 170 and 425 nodes, respectively. Production after one year of multiple harvests was 624 and 1324 orthotropic buds (Glicenstein *et al.*, 1990). Actually, the overall production of meristems in the present study may equal that reported by Glicenstein and colleagues, since a significant proportion of few node stem cuttings in the present study had two, three or more axillary meristems. As mentioned earlier, rooting of stem cuttings may be affected by the rooting hormone, variety,

phenology, phase, and quality of rooting material used, as well as the technique of the propagator. In the current study the growing conditions in the climate controlled greenhouse were maintained constant throughout the year. Therefore, variations in rooting success due to phenology were minimized, and successful rooting occurred throughout the course of the study. While only a single clone was tested in the current work, it had previously been shown to be the most responsive genotype in the SE protocol, grew vigorously and rooted readily. While the orthotropic SE-derived stock plants rooted well, stem cuttings harvested from fan branches of the original original tree (PSU-Sca6), from which flower buds were collected at the initiation of SE, had relatively poor rooting success at the same auxin concentrations (data not shown).

#### *Examination of Rooted Cutting Production and Extrapolation to a Clonal Garden Scale*

As presented in the current study, cacao germplasm may be multiplied *in vitro*, and the resulting plantlets may then be maintained in a climate-controlled greenhouse as nursery stock plants creating high-density clonal gardens for use in rapid and intensive multiplication of orthotropic material. Both softwood and bent semi-hardwood SE stock plant experimental clonal gardens were developed and may be useful for international and regional distribution of elite cacao clonal varieties with seedling-like architecture.

Softwood SE plants may be harvested prior to jorquette development beginning at two to four months, and their chupons utilized for rooted stem cuttings. A single stock plant harvested in the above manner produces approximately 70 rooted cuttings in the first year and reaches a productivity of 240 cuttings  $y^{-1}$  after a six to eight month establishment phase.

SE plants may also be maintained until phase change from juvenile orthotropic growth to mature plagiotropic growth (semi-hardwood stage). If the newly formed fan branches are removed and the trunks are bent to horizontal, chupons will proliferate from release of axillary orthotropic meristems along the trunk. In the first year, approximately 250 rooted cuttings may be harvested per stock plant, and productivity may reach over 350 cuttings  $y^{-1}$ .

If maintained at high densities and in an optimal growth environment, softwood and semi-hardwood stock plants from SE-derived clone PSU-Sca6 have been demonstrated to yield rooted cuttings at approximately 1,250 cuttings  $m^{-2}$  bench top  $y^{-1}$  and 500  $m^{-2} \cdot y^{-1}$ , respectively.

A preliminary study noted the production of single-node, orthotropic softwood stem cuttings from stock plants derived from bent, semi-hardwood 2°SE derived cacao plants (Guiltinan *et al.*, 2000). However, the methods by which orthotropic cuttings were produced or how stock plants were maintained were not detailed. The current study attempts to address quantitatively an effective strategy to merge *in vitro* and traditional vegetative propagation avenues into the development of efficient, orthotropic clone nursery production systems of improved cacao varieties.

## CHAPTER 3

### DEVELOPMENT AND PHYSIOLOGY OF CLONAL CACAO: GREENHOUSE COMPARISON OF JUVENILE PLANTS FROM SOMATIC EMBRYOGENESIS AND ORTHOTROPIC ROOTED STEM CUTTINGS TO SEEDLINGS.

*“It is widespread belief among planters that a tree raised from a rooted cutting or sucker fails to form a good root system, and that in consequence, the sapling does not develop into a healthy bearing tree. In particular, with cacao trees, it is stated that when they have been raised from detached suckers- ‘chupons’ –they do not develop a tap-root, and that therefore they will be of no value, as, for some reason, great importance seems to be place on the presence of a tap-root. Granted that no vegetatively raised individual can develop a true tap-root, in cacao the supposition that basal suckers do not develop main roots, which function exactly similarly, is untrue; most ‘chupons’ which have rooted on the trees have a main root when they are young, and if this subsequently decays it must indicate that the soil conditions are not suited to its persistence.” -E.E. Pyke (1932a)*

#### Introduction

Somatic embryogenesis in cacao has been the focus of various research programs since the 1970s (reviewed in Gultinan, 2007). Advances in somatic embryogenesis at the Pennsylvania State University (PSU) have led to a significantly improved efficiency in the production of cacao somatic embryogenesis (Li *et al.*, 1998; Antúnez de Mayolo *et al.*, 2002; Maximova *et al.*, 2002). Somatic embryo cacao trees have been established in several field tests as cited earlier and reviewed in Gultinan (2007). These SE-derived plants show true-to-type growth and precocious development in the field and hold potential promise for commercial application in the large-scale multiplication of elite and resistant germplasm (Maximova *et al.*, 2008). Theoretical production yields of tissue

culture-based vegetative propagation by the SE protocol at PSU has been calculated at 800,000 clonal plants from a single flower in two years (Maximova *et al.*, 2005).

However, in a practical context, SE is limited by poor germination of embryos, and effects of genotype may necessitate customization of the protocol for each clone of interest (Jain, 2006). As well, any *in vitro* system requires significant investment in facilities, equipment, supplies, and personnel to approximate theoretical production estimates.

A way to address some of these challenges and overcome several of the limitations inherent to somatic embryogenesis is to apply appropriate greenhouse and nursery vegetative propagation techniques after acclimation of *in vitro* plants. Previous research (conducted concomitantly with the current study) suggested that acclimated SE plants could be developed into and maintained as softwood stock plants shortly after acclimation in the greenhouse, and chupons produced were also very suitable to greenhouse propagation of single node orthotropic softwood stem cuttings (Lambert *et al.*, 2000). When grown in appropriate greenhouse conditions, increased growth rate of greenhouse raised versus tissue culture raised plants allows for significantly greater plant biomass production *ex vitro* during the same time period than in Magenta vessels maintained in a growth chamber. In this sense, increased biomass production also has a direct correlation with the number of meristematic buds produced, each of which may then be converted into a separate plant either by *in vitro* micropropagation (Glicenstein *et al.*, 1990), bud grafting or, as demonstrated earlier, by the rooting of single node stem cuttings. SE plants that are efficiently converted into stock plants and well managed, as presented in Chapter 2, produce orthotropic chupons used for making rooted cuttings

with seminal-like architecture. Clonal production from softwood stock plants can significantly increase clonal production relative to *in vitro* micropropagation.

As well, results from investigations into the bending to horizontal of seminal plants to stimulate chupon production appeared as if it would also readily adapt to SE-derived cacao (Amefia *et al.*, 1985; Glicenstein *et al.*, 1990; Bertrand and Dupois, 1992; Efron, 1999). Previously bent stock plants (from Chapter 2) originated from preliminary observations on work carried out in the Program in the Molecular Biology of Cacao PSU to adapt *ex vitro* SE plants to production of orthotropic softwood stem cuttings. What warranted further investigation in the current case was the determination of whether orthotropic clonal plants propagated by these rapid greenhouse methods for orthotropic clonal propagation grew true to type. As well, it would be informative to understand what, if any, developmental or growth differences existed between clonally propagated orthotropic plants and their half sib seedlings.

The goal of this portion of the project was the further investigation of the integrated orthotropic propagation system for cacao. Examination of comparative allometric development and growth of 1°SE, 2°SE, and orthotropic rooted cuttings from softwood stock plants (RC-SW), as well as of orthotropic rooted cuttings from semi-hardwood stock plants (RC-SHW) was undertaken. SE plants were staged from acclimation and were compared with directly sown seedlings and newly transplanted orthotropic rooted cuttings. Plants were followed from post-acclimation, germination, and bud break through the juvenile orthotropic developmental phase change that occurred mostly before one year.

## Materials and Methods

### *Plant Material and Greenhouse Conditions*

Primary somatic embryos (1°SE), 2°SE, orthotropic softwood rooted cuttings from 2°SE softwood stock plants (RC-SW), and orthotropic softwood rooted cuttings from bent 2°SE semi-hardwood stock plants (RC-SHW) were obtained as described in Chapter 2. SE plants were first transplanted from Magenta vessels into D-40-Deepots and acclimated for between 14 to 21 days under mist, low light, frequent drip irrigation with 1:10 strength nutrient solution, and generally saturated air moisture content (100% RH) as described in Chapter 2. This acclimation time was sufficient for 1 to 2 abbreviated growth flushes from 1 to 4 leaves each and establishment of the primary root system. Acclimated SE plants were then bare root transplanted a second time into 7.65L tree pots, 0.2 m X 0.2 m X 0.32 m (Stewie and Sons, Inc., Tangent, OR, U.S.A.). Rooted single node orthotropic stem cuttings were bare root transplanted into tree pots following 4 weeks adventitious rooting as described in Chapter 2. Seeds were obtained from open pollinated fruit harvested from the clone Scavina 6 at the USDA station in Mayaguez, Puerto Rico. Fruits were opened, seeds were washed in distilled deionized water, and the testa was removed to facilitate rapid germination. Seeds were then direct sown in tree pots at 20 mm depth.

Potting media was steam sterilized, coarse round grain sand (Flint Silica #13, U.S. Silica, Ottawa, IL, U.S.A.). Tree pots were filled to 20 mm below lip of pot, and potting media was pre-wetted with 1:10 strength modified complete nutrient solution at 150  $\mu$ M N prepared with distilled deionized water, final ph 6.5 (Hoagland and Arnon, 1950). Plants/seeds were watered in at transplant/sowing. Drip irrigation was supplied for



3 to 5 minutes until freely dripping from bottom of pots eight times per day with the 1:10 strength nutrient solution. Plants were grown on low benches (100 mm above floor) with grated aluminum surface. Spacing between rows was 1 m on center. Within row spacing was approximately 0.5, 0.6, and 0.8 m from center for growing periods of 1-4, 5-8, and 9-12 months, respectively.

Plants were grown in a climate controlled greenhouse with diffuse glazing under direct sun light, partial shade (during high light intensity), and supplemental light (during low light intensity). Daily growing period was 14/10 hour light/dark. Combined use of automatic overhead shade curtains and 430 watt high pressure sodium lamps maintained light levels between 400 to 1000  $\mu\text{mol}\cdot\text{m}^{-2}\cdot\text{sec}^{-1}$  PAR at canopy level during light hours. Lamps were suspended overhead between every second row on center, distributed every 2 m along the rows, and maintained at approximately 1.0 to 1.5 m above the canopy. Automatic overhead shade curtains and vertical blackout curtain (along west side of greenhouse) were maintained closed during all dark periods. Temperature and relative humidity were maintained at 28°/25° C day/night and 75% RH. Heating was by radiators and utilized in combination both passive (north and south sides) and forced air (west to east). Cooling was managed via a combination of forced air ventilation (west to east and overhead) and forced air heat pumps. An overhead fog system maintained RH at set levels.

### *Experimental Design and Analysis*

An experiment was carried out to examine the development of juvenile, container grown orthotropic softwood rooted cuttings from bent semi-hardwood stock plants (RC-SHW). Rooted single node stem cuttings were bare root transplanted to tree pots and

grown under the conditions described above without a hardening off period. Plants were grown until the transition from juvenile (orthotropic) phase to mature (plagiotropic) phase. Phase change was noted by the appearance and development of the first jorquette (compact whorl of plagiotropic axillary meristems). Phase change occurred at mostly between 2 to 6 months following transplant. After appearance of the jorquette, the main axis was tipped 10 mm below the whorl of plagiotropic meristems. After the heading cut, a single axillary meristem that subtended the cut broke dormancy, grew, was allowed to continue orthotropic growth until development of a second jorquette. Height was measured as the distance from the base of the trunk to first jorquette scar and second jorquettes. Two variables were tested: 1) ordinal position of stem cutting from along the harvested chupon taken from the stock plant (cutting taken from chupon apex = position 1, increasing basipetally [see Figure 2.5]); and 2) distance of harvested chupon from the base of the trunk (see Figure 2.3-c, -d). Experimental arrangement was a completely randomized design (n=68). Data were analyzed by scatter plot.

A second experiment was carried out to characterize the juvenile development of container grown seedlings, 1°SE, 2°SE, orthotropic softwood rooted cuttings from bent 2°SE semi-hardwood stock plants (RC-SHW), and orthotropic softwood rooted cuttings from 2°SE softwood stock plants (RC-SW). Thirty plants each of the five propagation methods were planted in tree pot containers as described above. Experimental arrangement of treatments was a completely randomized design with 3 replications (destructive harvests) each consisting of 10 repetitions per treatment per harvest. Harvests were made at 4, 8, and 12 months after direct sowing (seeds) and transplanting. Variables measured were height/jorquette height, stem diameter at base of trunk, stem diameter at

0.5 m above base of trunk, number of plagiotropic branches formed at the jorquette. Leaf area was measured on leaf laminae with a LI-COR model LI-3000A Area Meter. Petioles were treated as stem material. Root systems were removed from pots and thoroughly washed to remove all sand particles. The number of main orthogeotropic tap roots and framework roots (seminal and adventitious) was counted. Leaf, stem, and root materials were bagged and placed in convection oven at 60°C until dried, and dry weights were obtained. Specific leaf area (SLA) was calculated from the total leaf area per total leaf dry weight. As plants were determined to be heavily pot bound by the third harvest (12 months), root dry weights were not taken for this harvest.

ANOVA was done using the software package Minitab release 14, Minitab, Inc., State College, PA, U.S.A. Allometric coefficient analysis was done using the software package R release 2.8.1 ([www.r-project.org](http://www.r-project.org)) and following those methods of Faraway, 2005.

## Results

Orthotropic rooted cuttings from chupons of semi hardwood stock plants (RC-SHW) were grown until the juvenile/mature phase change (n=68). Mean first jorquette height as measured from the base of the trunk at soil level was  $0.73 \pm 0.06$  m. When jorquette height was considered relative to the position (node) of the rooted cutting taken from along the harvested shoot used for stem cutting material (see Figure 2.5), a skewed distribution was noted (Figure 3.1). Jorquette height among RC-SHW originating from stem cuttings taken near the top of a chupon (positions 1 – 5) varied about the mean, while all cuttings from positions 6 through 18 fell at or below the mean. If left to grow

Figure 3.1. Distribution of first jorquette height in rooted cuttings from chupons of semi-hardwood bent stock plants.

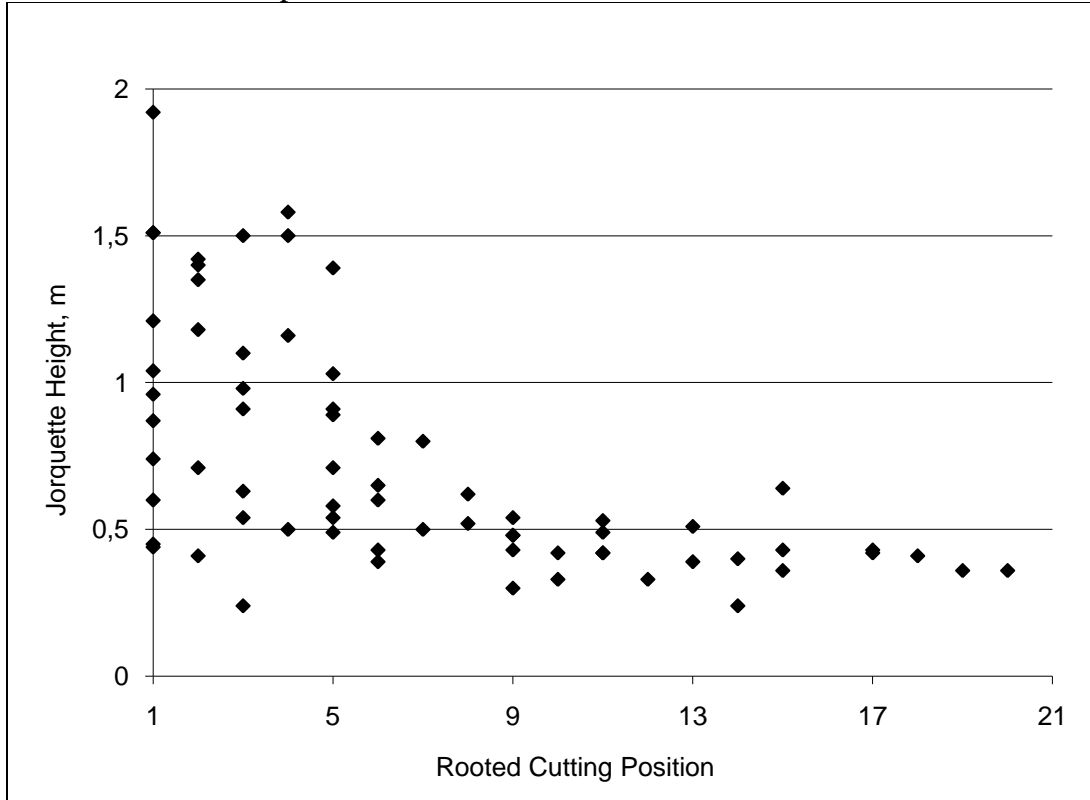

Jorquette height (m) of softwood orthotropic rooted cuttings (n=68) from bent semi hardwood stock plants (RC-SHW) relative to the position (node) along chupon from which the cutting originated (see Figure 2.4 above). Cuttings for sticking were taken first from the chupon apex (rooted cutting position 1) and further down the stem sequentially increasing position towards the base of the harvested chupon. After rooting, cuttings were transplanted and grown until development of the first jorquette. Mean jorquette height 0.73 m ( $\pm 0.06$  standard error of the mean).

without application of any cultural management, these trees would have developed a low canopy over a significantly short single orthotropic main trunk relative to seminal plants.

Instead, the main orthotropic growing axis was tip pruned 10 mm below the newly formed jorquette as shown in Figure 3.2. Figure 3.2-a shows the apex of the orthotropic main axis of an RC-SHW with a newly formed jorquette above the pruning shear. The jorquette in this case depicted was composed of 4 plagiotropic meristems. Figure 3.2-b depicts the same axis after tipping. This completed the first phase of the

Figure 3.2. Heading cut (tipping) applied to first jorquette, regrowth of orthotropic axis, and development of second jorquette.

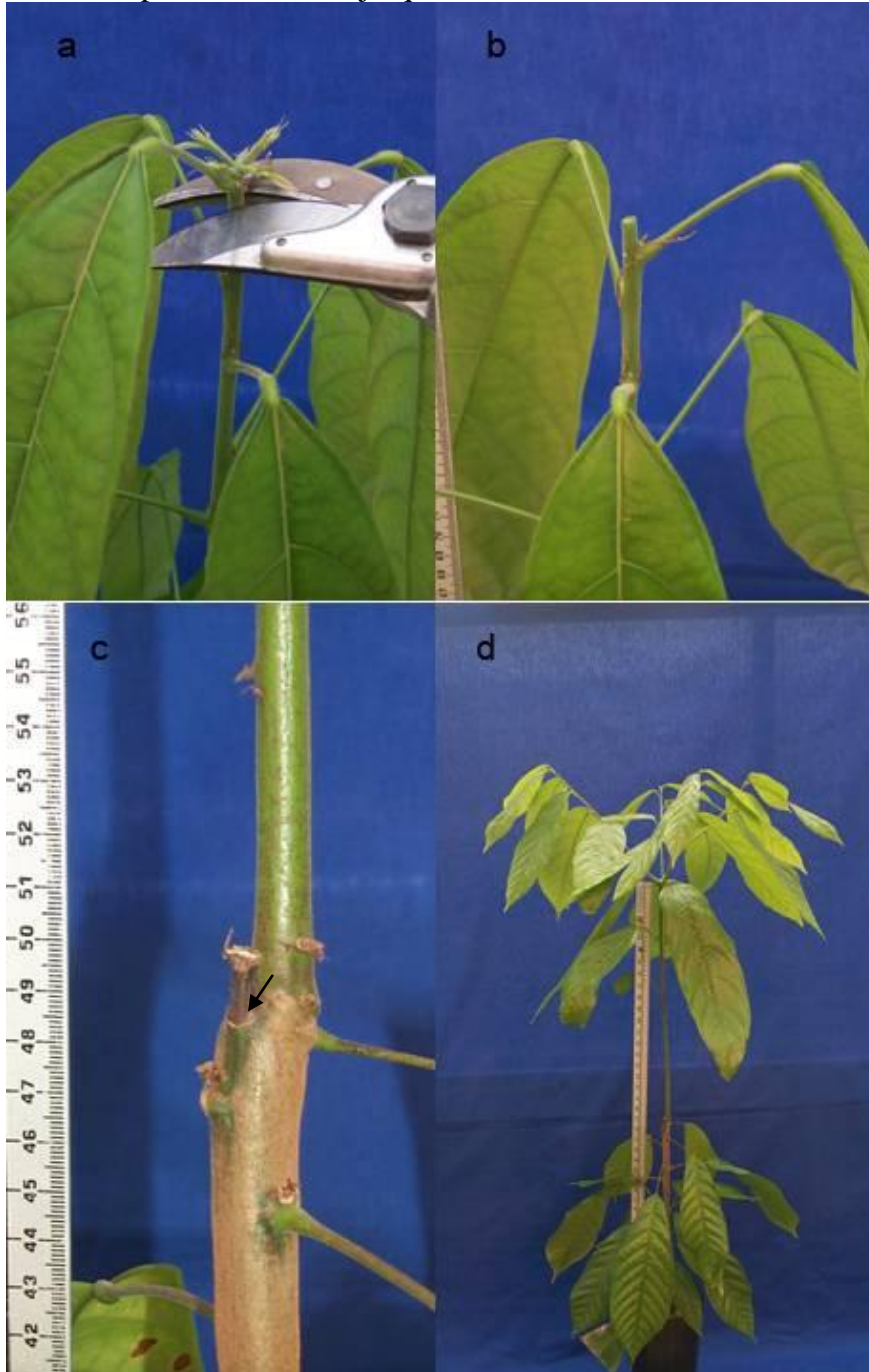

Two stages are shown from the heading cut (tipping) management technique applied to an orthotropic rooted cutting propagated from the chupon of a bent semi-hardwood stock plant (RC-SHW). Stage one a) depicts an orthotropic axis with newly formed jorquette seen above the pruning shear and b) the same axis after a strong heading cut 10 mm below the jorquette. Stage two at four to six months after removal of first jorquette c) shows close-up at semi-hardwood stage of primary orthotropic axis and orthotropic regrowth at greenwood stage from a subtending axillary chupon. A second axillary orthotropic axis (desiccated, dark brown) was pruned to limit regrowth to a single orthotropic axis. The same container grown tree is shown at a distance d) demonstrating the orthotropic regrowth after the strong heading cut and second jorquette.

specific management that promoted further orthotropic growth prior to the formation of a canopy.

A second RC-SHW plant is depicted in Figure 3.2-c, and Figure 3.2-d after regrowth of an axillary orthotropic meristem that subtended the tipped jorquette. Figure 3.2-c is a close-up photo demonstrating the original orthotropic axis (below junction) at the semi-hardwood stage, while the axillary orthotropic shoot (above junction) appears as greenwood. At the junction a second (now dessicated) orthotropic meristem had been previously pruned to ensure that only one orthotropic axillary shoot (chupon) remained to develop as the principle orthotropic axis/trunk. After tipping the first jorquette meristem, plants were maintained in the greenhouse under the same growing conditions until the development of a second jorquette (Figure 3.2-d). Mean height of second jorquette was  $1.54 \pm 0.08$  m from the base of the trunk (n=68).

A second experiment compared the development and growth of 1) seedlings, 2) 1°SE, 3) 2°SE, 4) orthotropic softwood rooted cuttings from bent 2°SE semi-hardwood stock plants (RC-SHW), and 5) orthotropic softwood rooted cuttings from 2°SE softwood stock plants (RC-SW). Figure 3.3 depicts greenhouse container grown plants at four months post sowing/transplant. Bare root plants are shown after their removal from pots and washing away with water of the silica sand potting media from root systems. A seedling with single tap root is shown in Figure 3.3-a. The presence of hypocotyl, cotyledon scars, and epicotyl in seedlings (not depicted) assists in distinguishing seedlings from 1°SE and 2°SE, which are shown in Figures 3.3-b and 3.3-c. An important characteristic of SE stem morphology is the presence of many small leaf scars at short internodes along the portion of the stem beginning at planting depth. These arise from

Figure 3.3. Bare root juvenile orthotropic plants and plagiotropic rooted cutting at four months growth in greenhouse.



Plants were grown in greenhouse four months after sowing/transplanting in 7.65L tree pots with silica sand potting media, then washed with water to show root system development; a) seedling, b) primary somatic embryo, c) secondary somatic embryo, d) orthotropic rooted cutting from bent semi-hardwood stock plant, e) orthotropic rooted cutting from softwood stock plant, f) plagiotropic rooted cutting from PSU-Sca6 plagiotropic grafted scion.

the many leaves produced from *in vitro* conversion through acclimation and establishment (see Figure 2.2-a). Additionally, as seen in Figures 2.2-a and 3.3-b, SE plants have a tendency to produce multiple orthotropic shoots, some of them axillary shoots (chupons or suckers) at or near the plant base. In contrast, the bark of seminal juvenile plants is smooth below the cotyledon scars as well as above the cotyledon scars until the seed leaves or their scars. While a 1°SE is seen (Figure 3.3-b) with one tap root, SE plants many times developed more than one primary tap root. Figure 3.3-c shows a 2°SE with a bifurcated root system that was scored as having two tap roots.

Rooted cuttings are shown in Figure 3.3-d, 3.3-e, and 3.3-f. The RC-SHW depicted (Figure 3.3-d), has at least two adventitious framework roots that may be distinguished from the photo. A close-up photo of an RC-SW is seen in Figure 3.3-e with at least three adventitious framework roots.

A plagiotropic rooted cutting (Figure 3.3-f) demonstrates the contrasting shoot architecture of these plants to orthotropic clones. The bush-like habit is similar to that of a single plagiotropic main canopy branch arising at the jorquette. This architecture resulted from the plagiotropic axillary meristem that gave rise to the rooted cutting. The plagiotropic rooted cutting has one principle adventitious framework root seen at an angle of approximately 30° to the right of vertical in the photo. Plagiotropic rooted cuttings were not included in the experiment. A preliminary experiment did, however, include plagiotropic rooted cuttings, and these demonstrated similar development as reported in the literature as well as similar growth as compared to the orthotropic plants. Plagiotropic rooted cuttings were not included in the experiment reported herein, due to the propensity to induce shading among the other plants due to the lateral, unbalanced growth habit of



these plants, which was exacerbated in the current instance because of greenhouse space limitations.

Representative examples of container grown orthotropic trees after 12 months growth in the greenhouse are shown in Figure 3.4 (upper photo). Beginning from left to right they are a) seedling, b) 1°SE, c) 2°SE, d) RC-SHW, e) RC-SW. All trees shown demonstrate the transition to adult phase by the presence of a jorquette. However, many RC-SW (far right) had yet to develop a jorquette by twelve months growth. Figure 3.4 (lower photo) depicts two to three principle tap and framework root systems, seminal and adventitious, respectively, with the main feeder roots removed. These were selected from the same treatments depicted directly above the root systems and preceded by the same letters.

Plant height, the distance from the base of the trunk from surface of potting media acropetally along the main axis to either the apical meristem or the first jorquette (if present), was determined at three harvests (Table 3.1). By 12 months after sowing/transplant, all the plants except 7 RC-SW plants had one jorquette. Mean plant/jorquette height as shown in Table 3.1 for 1°SE and 2°SE were  $2.11 \pm 0.17$  m and  $2.04 \pm 0.10$  m, respectively. SE plants were significantly taller than seedlings at the jorquette ( $1.62 \pm 0.08$  m) and RC-SHW ( $1.48 \pm 0.10$  m) at  $p \leq 0.05$ . RC-SHW was the lowest jorquetting tree among treatments ( $p \leq 0.05$ ), and it should be noted that all RC-SHW had jorquitted for the second time by 12 months growth; the first jorquette had been removed by tipping the jorquette bud (see above). Mean number of plagiotropic branches at the jorquette was consistent among all treatments and ranged from a high of  $5.3 \pm 0.3$  to a low of  $4.7 \pm 0.4$  plagiotropic branches per jorquette (Table 3.1). Numbers

Figure 3.4. Orthotropic trees and primary root systems after twelve months in greenhouse.



Top: Orthotropic trees grown in the greenhouse for twelve months. Bottom: primary root systems, each from a different plant, that were grown in the greenhouse for twelve months after sowing/transplanting in 7.65L tree pots with silica sand potting media, then washed with water and trimmed of all but primary roots to show root system development; a) seedling, b) primary somatic embryo, c) secondary somatic embryo, d) orthotropic rooted cutting from semi-hardwood stock plant, e) orthotropic rooted cutting from softwood stock plant.

Table 3.1. Juvenile growth of seedlings, somatic embryos, and orthotropic rooted cuttings at 4, 8, and 12 months.

Harvest	Plant Type	Height, m	SD @ base, mm	SD @ 0.5m, mm	Plagio	Tap/Framework Root
1	Seed	0.54 ± 0.02a	8.7 ± 0.2a	-	-	1.0 ± 0.0a
1	1°SE	0.43 ± 0.05b	8.6 ± 0.7a	-	-	1.4 ± 0.2b
1	2°SE	0.41 ± 0.04b	8.0 ± 0.4a	-	-	1.4 ± 0.2b
1	RC-SHW	0.41 ± 0.05b	7.5 ± 0.2a	-	-	5.6 ± 0.6c
1	RC-SW	0.38 ± 0.04b	5.9 ± 0.5b	-	-	2.6 ± 0.6b
2	Seed	1.40 ± 0.09a	16.1 ± 0.6	11.4 ± 0.5	5.3 ± 0.3	1.0 ± 0.0a
2	1°SE	1.28 ± 0.05ab	15.4 ± 0.4	9.9 ± 0.3	5.0 ± 0.0*	2.1 ± 0.4b
2	2°SE	1.43 ± 0.08a	16.1 ± 0.7	10.8 ± 0.5	5.0 ± 0.0*	2.3 ± 0.3b
2	RC-SHW	1.21 ± 0.09b	14.5 ± 0.6	9.6 ± 0.5	4.7 ± 0.4	3.8 ± 0.4c
2	RC-SW	1.36 ± 0.10ab	14.8 ± 0.7	10.1 ± 0.7	5.0 ± 0.0*	3.0 ± 0.4bc
3	Seed	1.62 ± 0.08bc	23.7 ± 0.9a	17.1 ± 0.8a	4.9 ± 0.1	1.0 ± 0.0a
3	1°SE	2.11 ± 0.17a	23.5 ± 1.8a	16.1 ± 1.7a	5.0 ± 0.0	1.8 ± 0.5b
3	2°SE	2.04 ± 0.10a	25.5 ± 0.9a	17.1 ± 0.6a	5.1 ± 0.1	2.0 ± 0.2b
3	RC-SHW	1.48 ± 0.10c	24.1 ± 0.7a	16.4 ± 0.5a	5.1 ± 0.2	4.6 ± 0.4c
3	RC-SW	1.73 ± 0.13ab	17.9 ± 0.8b	12.1 ± 0.5b	5.1 ± 0.2**	2.1 ± 0.3b

Destructive harvests (3) of juvenile container grown orthotropic plants. Harvests 1, 2, and 3 were made at 4, 8, and 12 months post sowing/transplant, respectively, for five plant types: 1) seedlings (Seed); primary somatic embryos (1°SE); secondary somatic embryos (2°SE); orthotropic rooted cuttings from 2°SE semi-hardwood stock plants (RC-SHW); orthotropic rooted cuttings from 2°SE softwood stock plants (RC-SW). Measurements taken were: height (m), distance from base of trunk to apical meristem or jorquette; stem diameter at base of trunk (SD @ base, mm); stem diameter at 0.5 m above base of trunk (SD @ 0.5, mm); number of plagiotropic branches arising at jorquette (Plagio); number of tap / framework roots and principle orthogeotropic adventitious roots (Framework Root). Values represent mean (± standard error of the mean) from ten repetitions. Values for the same harvest and followed by the same letter are not significantly different according to ANOVA post hoc test (p≤0.05). \* indicates a single observation. \*\* indicates 3 observations. Continues next 2 pages.

Table 3.1 (Continued 1). Juvenile growth of seedlings, somatic embryos, and orthotropic rooted cuttings at 4, 8, and 12 months.

Harvest	Plant Type	LA, m <sup>2</sup>	Leaf DW, g	Stem DW, g	Shoot DW, g	Root DW, g	Plant DW, g
1	Seed	0.23 ± 0.02a	6.8 ± 0.5a	4.1 ± 0.5a	10.9 ± 0.9a	1.7 ± 0.9	12.6 ± 3.8
1	1°SE	0.18 ± 0.03a	5.4 ± 1.0a	2.9 ± 0.7ab	8.3 ± 1.7a	2.0 ± 1.1	10.2 ± 6.5
1	2°SE	0.19 ± 0.03a	5.0 ± 0.9a	2.8 ± 0.9ab	7.8 ± 1.7a	2.2 ± 2.0	10.0 ± 7.4
1	RC-SHW	0.21 ± 0.03a	6.2 ± 0.7a	3.8 ± 0.5a	10.0 ± 1.1a	2.5 ± 0.6	12.5 ± 4.2
1	RC-SW	0.12 ± 0.02b	2.9 ± 0.4b	1.8 ± 0.3b	4.7 ± 0.7b	1.0 ± 0.4	5.7 ± 2.5
2	Seed	1.22 ± 0.12a	55.8 ± 5.4a	45.6 ± 5.8a	101.4 ± 10.9a	22.4 ± 7.2	123.9 ± 40.6
2	1°SE	0.88 ± 0.05b	37.4 ± 3.1b	30.0 ± 2.7b	67.5 ± 5.8b	21.2 ± 6.6	88.6 ± 24.3
2	2°SE	1.05 ± 0.09ab	46.0 ± 4.8ab	37.3 ± 5.3ab	83.3 ± 10.1ab	26.1 ± 8.9	109.4 ± 40.0
2	RC-SHW	0.89 ± 0.07b	39.0 ± 3.5b	29.3 ± 3.9b	68.3 ± 7.2b	22.5 ± 10.0	90.8 ± 35.5
2	RC-SW	0.86 ± 0.10b	37.9 ± 4.1b	30.1 ± 3.5b	68.0 ± 7.6b	20.6 ± 3.1	90.8 ± 18.4
3	Seed	3.45 ± 0.34a	173.5 ± 17.6a	200.4 ± 20.8a	373.9 ± 37.8a	-	-
3	1°SE	3.02 ± 0.71ab	141.2 ± 39.6ab	122.7 ± 28.7b	264.0 ± 66.3b	-	-
3	2°SE	3.40 ± 0.22a	157.2 ± 12.4ab	185.8 ± 19.6a	343.0 ± 31.2ab	-	-
3	RC-SHW	2.79 ± 0.15b	133.7 ± 9.3b	126.6 ± 10.2b	260.3 ± 19.2b	-	-
3	RC-SW	1.71 ± 0.15c	64.3 ± 7.9c	55.4 ± 8.4c	119.7 ± 16.2c	-	-

Destructive harvests (3) of juvenile container grown orthotropic plants. Harvests 1, 2, and 3 were made at 4, 8, and 12 months post sowing/transplant, respectively, for five plant types: 1) seedlings (Seed); primary somatic embryos (1°SE); secondary somatic embryos (2°SE); orthotropic rooted cuttings from 2°SE semi-hardwood stock plants (RC-SHW); orthotropic rooted cuttings from 2°SE softwood stock plants (RC-SW). Measurements taken were: leaf area, (LA, m<sup>2</sup>), leaf dry weight (Leaf DW, g); stem = trunk + branch + petiole dry weight (Stem DW, g); shoot = leaf + stem dry weight (Shoot DW, g); root = principle + coarse + fine root dry weight (Root DW, g); plant = shoot + root dry weight (Plant DW, g). Values represent mean (± standard error of the mean) from ten repetitions. Values for the same harvest and followed by the same letter are not significantly different according to ANOVA post hoc test (p≤0.05). Continues next page.

Table 3.1. (Continued 2). Juvenile growth of seedlings, somatic embryos, and orthotropic rooted cuttings at 4, 8, and 12 months.

Harvest	Plant Type	SLA, m <sup>2</sup> ·kg <sup>-1</sup>	R:S
1	Seed	34.9 ± 6.2	0.15 ± 0.05
1	1°SE	36.7 ± 8.3	0.25 ± 0.06
1	2°SE	37.7 ± 7.3	0.27 ± 0.07
1	RC-SHW	32.6 ± 4.7	0.26 ± 0.05
1	RC-SW	41.6 ± 6.5	0.23 ± 0.07
2	Seed	22.0 ± 2.5	0.23 ± 0.05
2	1°SE	23.9 ± 1.6	0.31 ± 0.05
2	2°SE	23.3 ± 1.6	0.32 ± 0.05
2	RC-SHW	24.0 ± 6.4	0.34 ± 0.11
2	RC-SW	22.7 ± 3.4	0.33 ± 0.10
3	Seed	20.8 ± 3.0	-
3	1°SE	23.0 ± 4.7	-
3	2°SE	22.1 ± 2.4	-
3	RC-SHW	21.5 ± 2.5	-
3	RC-SW	27.7 ± 3.5	-

Destructive harvests (3) of juvenile container grown orthotropic plants. Harvests 1, 2, and 3 were made at 4, 8, and 12 months post sowing/transplant, respectively, for five plant types: 1) seedlings (Seed); primary somatic embryos (1°SE); secondary somatic embryos (2°SE); orthotropic rooted cuttings from 2°SE semi-hardwood stock plants (RC-SHW); orthotropic rooted cuttings from 2°SE softwood stock plants (RC-SW). Calculations made were: root to shoot ration, g:g (R:S); specific leaf area (SLA, m<sup>2</sup>·kg<sup>-1</sup>); leaf area to root dry weight (LA:Root DW, m<sup>2</sup>·kg<sup>-1</sup>). Values represent mean (± standard error of the mean) from ten repetitions.

of seminal tap roots and adventitious framework roots were counted at all three harvests. As shown in Table 3.1, seedlings produced a single tap root in all cases observed, and the other treatments produced in some instances a single tap root or framework root (or one which bifurcated) or, more commonly, greater than one tap/framework root. Table 3.1 shows that both 1°SE and 2°SE plants produced from  $1.4 \pm 0.2$  to  $2.3 \pm 0.3$  tap roots, and this was significantly less than the number of adventitious framework roots observed in RC-SHW, which ranged from  $3.8 \pm 0.4$  to  $5.6 \pm 0.6$  ( $p \leq 0.05$ ).

Stem diameter (SD) is a strong determinant of tree vigor and is shown at both the base of the trunk and at 0.5 m above trunk base in Table 3.1. Combined mean SD at base of trunk at the 1<sup>st</sup> harvest was 7.7 mm and ranged from  $5.9 \pm 0.5$  mm to  $8.7 \pm 0.2$  mm for RC-SW and seedlings, respectively. By the 3<sup>rd</sup> harvest SD at base of trunk ranged from  $23.5 \pm 1.8$  mm to  $25.5 \pm 0.9$  mm for 1°SE and 2°SE, respectively. Table 3.2 shows relative growth rate (RGR) over the 4-month growth periods for SD at base of trunk from 1<sup>st</sup> to 2<sup>nd</sup> harvests ranged from  $0.85 \text{ g} \cdot \text{g}^{-1} \cdot 4\text{-month}^{-1}$  for seedlings to  $1.51 \text{ g} \cdot \text{g}^{-1} \cdot 4\text{-month}^{-1}$  for RC-SW and from  $0.21 \text{ g} \cdot \text{g}^{-1} \cdot 4\text{-month}^{-1}$  for RC-SW to  $0.66 \text{ g} \cdot \text{g}^{-1} \cdot 4\text{-month}^{-1}$  for RC-SHW for the period from the 2<sup>nd</sup> to 3<sup>rd</sup> harvest. Stem diameter at base of trunk RGR slowed for all treatments from the first to the second growth period, and this reduction was most profound for RC-SW. As plants had not grown sufficiently by harvest one to allow for measurement, SD at 0.5 m from base of trunk was only reported for 2<sup>nd</sup> and 3<sup>rd</sup> harvests (Table 3.1). Combined mean SD at 0.5 m above the base of the trunk was approximately 10.4 mm at 2<sup>nd</sup> harvest and increased 1.5 times by the 3<sup>rd</sup> harvest to approximately 15.8 mm. At the 3<sup>rd</sup> harvest, SD at 0.5 m above the base of the trunk ranged from  $12.1 \pm 0.5$  mm for RC-SW to  $17.1 \pm 0.6$  mm for seedlings and 2°SE,

Table 3.2 Relative growth rates of juvenile growth of seedlings, somatic embryos, and orthotropic rooted cuttings between 4 to 8, and 8 to 12 months.

Period	Plant Type	SD @ base	SD @ 0.5m	LA	Leaf DW	Stem DW	Shoot DW	Root DW	Plant DW
1-2	Seed	0.85	-	4.30	7.21	10.12	8.30	12.18	8.33
1-2	1°SE	0.79	-	3.89	5.93	9.34	7.13	9.6	7.69
1-2	2°SE	1.01	-	4.53	8.20	12.32	9.68	10.86	9.94
1-2	RC-SHW	0.93	-	3.24	5.29	6.71	5.83	8.00	6.26
1-2	RC-SW	1.51	-	6.17	12.07	15.72	13.47	19.60	14.93
2-3	Seed	0.47	0.50	1.83	2.11	3.39	2.69	-	-
2-3	1°SE	0.53	0.63	2.43	2.78	3.09	2.91	-	-
2-3	2°SE	0.58	0.58	2.24	2.42	3.98	3.12	-	-
2-3	RC-SHW	0.66	0.71	2.13	2.43	3.32	2.81	-	-
2-3	RC-SW	0.21	0.20	0.99	0.70	0.84	0.76	-	-

Destructive harvests (3) of juvenile container grown orthotropic plants. Harvests 1, 2, and 3 were made at 4, 8, and 12 months post sowing/transplant. Relative growth rates (RGR) were calculated for the 4-month periods between harvests using the following units,  $\text{mm} \cdot \text{mm}^{-1} \cdot 4\text{-month}^{-1}$  (stem diameter- SD),  $\text{mm}^2 \cdot \text{mm}^{-2} \cdot 4\text{-month}^{-1}$  (leaf area- LA), and  $\text{g} \cdot \text{g}^{-1} \cdot 4\text{-month}^{-1}$  (for dry weights- DW).

respectively. RC-SW had significantly smaller SD than other treatments at both 1<sup>st</sup> and 3<sup>rd</sup> harvests ( $p \leq 0.05$ ).

RC-SW were smaller propagules than the other treatments at sowing/transplant, and this was indicated (Table 3.1) by the lowest 1<sup>st</sup> harvest means for 1) SD at base of trunk  $5.9 \pm 0.5$  mm, 2) leaf area (LA)  $0.12 \pm 0.02$  m<sup>2</sup>, and 3) shoot dry weight  $4.7 \pm 0.7$  g ( $p \leq 0.05$ ). However, RC-SW had the highest RGR for all variables measured from the 4 to 8 month period (Table 3.2), and fewer differences in these measured variables were evident by the 2<sup>nd</sup> harvest (Table 3.1). This improvement in growth did not hold later in the experiment, and for the second growth period, from 8 to 12 months, RGR was the lowest in all measured variables for RC-SW. By harvest 3, SD at base of trunk ( $17.9 \pm 0.8$  mm) and SD at 0.5 m above trunk ( $12.1 \pm 0.5$  mm) were only slightly above 2<sup>nd</sup> harvest values, and both stem diameters were approximately 25% less than means of the other four treatments combined (Table 3.1). At the 3<sup>rd</sup> harvest, RC-SW had approximately 55% of the leaf area and 45% of the shoot dry weight of other treatments ( $p \leq 0.05$ ). Only 3 of 10 RC-SW plants had formed a jorquette by the 3<sup>rd</sup> harvest. For these reasons, RC-SW were excluded from several comparisons that follow in some variables which utilize calculations of overall means.

Overall means were calculated for the combined four treatments 1) seedling, 2) 1°SE, 3) 2°SE, 4) RC-SHW for leaf area (LA), as well as leaf, stem, shoot, and root dry weight (data not shown). For the interval between 1<sup>st</sup> and 2<sup>nd</sup> harvests (4 – 8 months), LA, as well as leaf, stem, and root dry weight RGR was on average 5.3, 7.6, 10.5, and 11 g · g<sup>-1</sup> · 4-month<sup>-1</sup> respectively (Table 3.2). During this same interval, plant DW (shoots + roots) RGR was 9 g · g<sup>-1</sup> · 4-month<sup>-1</sup>. For the next interval between the 2<sup>nd</sup> and 3<sup>rd</sup> harvests (8 – 12



months), leaf area as well as leaf and stem, dry weight RGR was on average 3.2, 3.4 and 4.5  $\text{g} \cdot \text{g}^{-1} \cdot 4\text{-month}^{-1}$ , respectively (Table 3.2). Roots systems were not included in the 3<sup>rd</sup> harvest dry weights, as plants were determined to be pot bound (see Figure 3.4 upper photo).

Seedlings demonstrated the highest LA and dry weight values for shoot growth variables among treatments throughout the experiment as seen in Table 3.1. 2°SE did not differ significantly in LA, leaf DW, stem DW, and shoot DW from seedlings, although in each case, means for 2°SE were lower than those for seedlings at all three harvests. 1°SE grew similarly as 2°SE, but 1°SE had lower LA and above ground organ dry weights than seedlings at the 2<sup>nd</sup> harvest as well as lower stem and shoot DW at the 3<sup>rd</sup> harvest ( $p \leq 0.05$ ). Table 3.1 shows that at the 3<sup>rd</sup> harvest 1°SE had significantly less stem DW ( $122.7 \pm 28.7 \text{ g}$ ) than 2°SE ( $185.8 \pm 19.6$ ) at  $p \leq 0.05$ . As well, 1°SE had approximately 25% less shoot DW than 2°SE.

At the 1<sup>st</sup> harvest, RC-SHW had similar LA, as well as leaf, stem, and shoot DW as seedlings, 1°SE, and 2°SE. However, RC-SHW shoots were generally smaller than that for seedlings, 1°SE, and 2°SE at the 2<sup>nd</sup> harvest, and RC-SHW had significantly ( $p \leq 0.05$ ) lower LA and stem DW than 2°SE at the 3<sup>rd</sup> harvest (Table 3.1). Figure 3.5 displays the allometric relationship between LA and stem DW on a scatter gram depicting each observation made for harvests 1, 2, and 3 among the five treatments. Figure 3.5 shows the linear trend lines for the  $\log(10)$  transformed data for each treatment (dashed line = seedlings). From regression analysis, the allometric coefficient (K) for all treatments were compared. No differences were found among the allometric coefficients for LA in relation to stem DW (Figure 3.5).

Figure 3.5. Allometric relationship of leaf area to total plant dry weight in juvenile orthotropic trees.

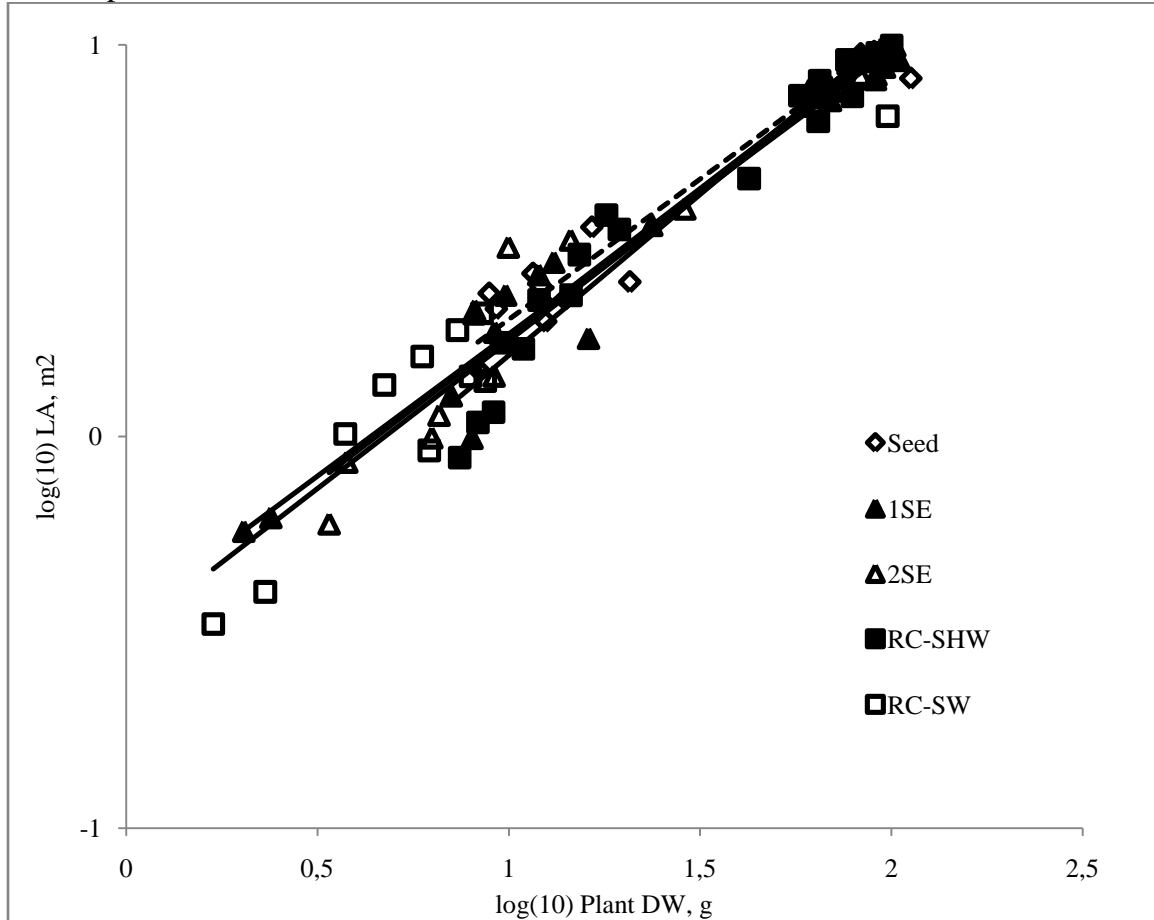

Total leaf area (LA, m<sup>2</sup>) is represented over total plant dry weight (Plant DW, g- combined leaf, trunk, stem, petiole, and root system) is represented after log(10) transformation for juvenile orthotropic container grown plants harvested at 4 and 8 months in greenhouse. Each plotted symbol represents an individual observation. The plotted treatment symbols, treatment abbreviations, equations for linear trend lines (slope equals allometric coefficient), and coefficients of regression (R<sup>2</sup>) are: ◇ seedling, (only dashed line)  $y = 0.7171x - 0.4187$ ,  $R^2 = 0.9693$ ; ▲ 1°SE,  $y = 0.7255x - 0.4644$ ,  $R^2 = 0.9641$ ; △ 2°SE,  $y = 0.7478x - 0.4891$ ,  $R^2 = 0.9678$ ; ■ RC-SHW,  $y = 0.8218x - 0.6151$ ,  $R^2 = 0.9474$ ; □ RC-SW,  $y = 0.7545x - 0.5108$ ,  $R^2 = 0.9633$ . Regression analysis of the slopes (allometric coefficients, K) indicated no significant differences among the treatments.

Table 3.1 shows specific leaf area (SLA) ranged from a low value of  $20.8 \pm 3.0$  (seedling, 3<sup>rd</sup> harvest) to a high of  $41.6 \pm 6.5$  (RC-SW, 1<sup>st</sup> harvest). While harvest effect was not tested, generally, SLA decreased in each successive harvest for seedlings, 1°SE, 2°SE, and RC-SHW. In contrast, RC-SW was the only treatment to show an increase in

SLA during the experiment. SLA increased in RC-SHW between the 2<sup>nd</sup> harvest and the 3<sup>rd</sup> harvest from  $22.7 \pm 3.4 \text{ m}^2 \cdot \text{kg}^{-1}$  to  $27.7 \pm 3.5 \text{ m}^2 \cdot \text{kg}^{-1}$ , respectively.

Root:shoot ratio (R:S) is shown in Table 3.1 and ranged between  $0.15 \pm 0.05$  and  $0.27 \pm 0.07$ , respectively for seedlings and 2<sup>o</sup>SE. R:S increased on average 34% from 1<sup>st</sup> to 2<sup>nd</sup> harvest for all treatments. In seedlings, R:S was the lowest when compared to other treatments at both 1<sup>st</sup> and 2<sup>nd</sup> harvests (Table 3.1). At the 2<sup>nd</sup> harvest seedling R:S had increased 80% to  $0.23 \pm 0.05$ . However, this increase by the 2<sup>nd</sup> harvest was still below the average R:S for other combined four treatments at 1<sup>st</sup> harvest (0.25). Among non-seedling treatments at the 2<sup>nd</sup> harvest, R:S ranged between  $0.34 \pm 0.11$  and  $0.31 \pm 0.05$  for RC-SHW and 1<sup>o</sup>SE, respectively (Table 3.1). Figure 3.6 displays log(10) transformed data for root DW and plant DW for each observation made for the 1<sup>st</sup> and 2<sup>nd</sup> harvests on a scatter gram. Linear trend lines were overlaid (dashed line = seedlings). From regression analysis of the allometric coefficient (K), seedlings demonstrate significantly higher allometric coefficient and lower intercept ( $P \leq 0.1$ ) for root DW over the range of plant DW observed compared to all other treatments.

## Discussion

### *General importance of dimorphism to cloning and consequences for orthotropic clones*

Interest in the clonal multiplication of the dimorphic materials available for cacao, i.e. orthotropic and plagiotropic, and their possible impact on production systems has intrigued researchers and growers for over seven decades (Pyke, 1933a, 1933b; Cheesman, 1935). Currently, accelerated clone development in Papua New Guinea utilizes the budding of orthotropic scion material from four to five-month-old seedlings,

Figure 3.6. Allometric relationship of root dry weight to total plant dry weight in juvenile orthotropic trees.

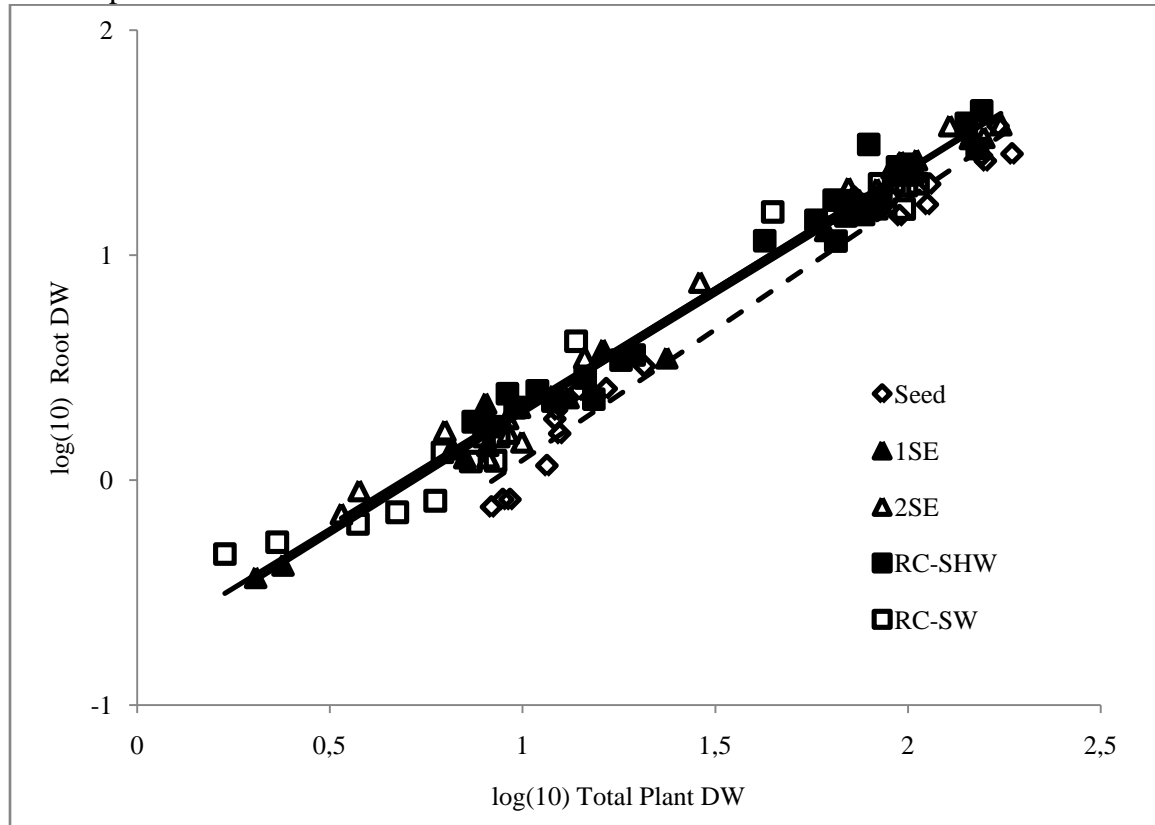

Root dry weight (DW, g), is represented over total plant dry weight (Plant DW, g- combined leaf, stem, trunk, petiole and root system) is shown after  $\log(10)$  transformation for juvenile orthotropic container grown plants harvested at 4 and 8 months after sowing/transplanting in greenhouse. Each plotted symbol represents an individual observation. The plotted treatment symbols, treatment abbreviations, equations for linear trend lines, and coefficients of regression ( $R^2$ ) are:  $\diamond$  seedling, (only dashed line)  $y = a1.1626x - 1.0748$ ,  $R^2 = 0.9765$ ;  $\blacktriangle$  1 $^{\circ}$ SE,  $y = b1.0729x - 0.7747$ ,  $R^2 = 0.9893$ ;  $\triangle$  2 $^{\circ}$ SE,  $y = b1.0514x - 0.7264$ ,  $R^2 = 0.9876$ ;  $\blacksquare$  RC-SHW,  $y = b1.0628x - 0.7441$ ,  $R^2 = 0.9721$ ;  $\square$  RC-SW,  $y = b1.0459x - 0.7413$ ,  $R^2 = 0.9764$ . Allometric coefficients (slopes, K) preceded by the same letter (a or b) are not significantly different at  $P \leq 0.1$ .

and later from these same seedling stock plants (ortets) (Efron, 1998; Efron *et al.*, 2000).

Budded orthotropic plants are used for rapid agronomic evaluation in breeding research and for their potential as new clones. In contrast, cacao producers in Trinidad are urged to manage plagiotropic rooted cuttings from established clones to produce basal chupons that are used to regenerate a clonal tree with an orthotropic architecture and an

adventitious, orthogeotropic framework root system (Mooleedhar, 2000; personal observation). Both of these conventional strategies bring together the concept of orthotropic clones. The former example begins with orthotropic material of untested origin, while the latter utilizes known plagiotropic clones with the aim of eventually attaining clones with orthotropic architecture.

Tissue culture via somatic embryogenesis offers the potential to mass propagate aseptic and virus free elite cacao germplasm (Quainoo *et al.*, 2008). Fontanel *et al.* (2002) reported the establishment in 2000 of three large field tests of “Arriba” cacao in Ecuador, Brazil, and Nigeria utilizing 5000 primary somatic embryos of cacao, and later, reported on the preliminary production from these tests (Masseret *et al.*, 2005). However, Fontanel and colleagues did not mention further *ex vitro* propagation of those SE-derived materials in either a greenhouse or a nursery. Furthermore, Lambert *et al.* (2000) investigated the potential of establishing SE-derived cacao in a nursery as a source of rooted cutting material.

Field tests examining the SE-derived plants utilizing the protocol developed at the Pennsylvania State University, both with and without further nursery multiplication, have been established in St. Lucia (Maximova *et al.*, 2008), Ghana, and Ecuador. A preliminary evaluation of the current study was made (Guiltinan *et al.*, 2000) and further reported on in Maximova *et al.* (2005). However, further investigation into the rapid nursery multiplication of SE-derived cacao was needed to examine how clonal orthotropic cacao developed relative to non-SE orthotropic cacao (i.e. seedlings). Maximova *et al.* (2008) reported the architecture of cacao from a 4.5-year field experiment which compared primary somatic embryos, secondary somatic embryos, *in*

*vitro* micropropagated trees, and orthotropic rooted cuttings. At 24 months post-acclimation (11 to 18 months in the greenhouse plus 6 months in field), 50% of trees had a jorquette, and after an additional year (36 months post-acclimation) 100% of plants had a jorquette. Interestingly, in the current study RC-SHW were the first to jorquette and only RC-SW did not jorquette in all cases after 12 months in the greenhouse, whereas Maximova and colleagues report that the time to jorquette was the longest for RC-SHW. However, RC-SW was not a treatment included in the study by Maximova and colleagues, and thus no comparison was possible. Regarding jorquette height, the first jorquette height for RC-SHW was higher in the current study than that reported by Maximova *et al.* (2008). Moreover, the current study reports significantly greater jorquette heights for seedlings, 1°SE, and 2°SE as well as a higher and more consistent number of jorquette branches in contrast with the findings of the study by Maximova *et al.* (2008). The aforementioned measurements are important as they indicate the normal development of a cacao tree (Maximova *et al.* 2008).

Plant architecture was evaluated over the course of one year and compared seedlings, 1°SE, 2°SE, RC-SHW, and RC-SW in the greenhouse. All plants examined formed one main trunk, a jorquette, and one or more tap or framework roots. Orthotropic rooted cuttings in cacao have been shown to have architecture similar to that of a seminal tree (Amefia *et al.*, 1985; Bertrand and Agbodjan, 1989). Bertrand and Dupois (1992) reported significantly lower jorquette height in orthotropic rooted cuttings than in seedlings. In that 1992 study jorquette height in cuttings ranged from 0.26 m to 0.95 m and was 1.5 m in seedlings. These results for jorquette height in both orthotropic rooted cutting and seedlings corroborate the findings in the current study. While significant

differences were noticed in jorquette height, stem diameter was the same between orthotropic rooted cuttings and seedlings (Bertrand and Dupois, 1992). As well, mean leaf, stem, and root growth on a dry weight basis was reported from orthotropic rooted cuttings of clones IMC 67 and T 12/5 as well as two hybrids GS 36xSNK 12 and P 7xSNK 48 (Bertrand and Dupois, 1992). From page 14 in the work of Bertrand and Dupois (1992), table III, last column on right, R:S, or root system fraction, is reported as the percentage of the root system to total plant weight. Orthotropic rooted cuttings were shown to have a higher R:S than seedlings. This same tendency was verified in the current work; RC-SHW, RC-SW as well as 1°SE, and 2°SE all had significantly greater R:S than seedlings at both 1<sup>st</sup> and 2<sup>nd</sup> harvests.

A similar technique of tipping back the first jorquette bud was undertaken on chupon scions grafted to seedling rootstocks in the nursery by Shepherd *et al.* (1981). Mean first jorquette height was 0.79 m ( $\pm 0.06$  SEM), which does not differ from the height of  $0.73 \pm 0.06$  m reported in the current study.

Efron (1999) reported the average height of jorquette in orthotropic budded seedlings in cacao. Orthotropic buds were harvested from 1) the main orthotropic axis of 4-month old seedlings as well as from 2) chupons that were released from seedlings receiving a strong head cut that was applied to the primary axis at 0.4 m above the base of the trunk. Another source of orthotropic budwood tested was described as originating from 3) an orthotropic budwood garden. A tree in an orthotropic budwood garden is shown, and this appears to be a coppiced three to five-year old tree with regrowth of chupons (suckers). These orthotropic materials were bud grafted onto four-month rootstocks. Mean jorquette heights of the budded seedlings were 1.20, 0.49, and

0.47 m for seedling main axis, chupons from seedlings, and chupons from coppiced trees, respectively. Jorquette height from seedling main axis, 1.20 m, most closely approximates jorquette height in the current study for RC-SW,  $1.73 \pm 0.13$  m, while, jorquette height from budwood arising from both seedling chupons and chupons from coppiced trees most closely resembles results in the current study for first jorquette height in RC-SHW of  $0.73 \pm 0.06$  m. Differences between these two systems utilized by Efron might be explained by differences in the origin of materials used. As the materials Efron took for budwood arose from higher on the main axis, or from more mature established stock plants in the case of coppiced trees than in the current study, this may have contributed to the more rapid transition of the scions to the adult phase as noted by generally lower jorquette formation compared to the current study. Additionally, the differences noted may have arisen from an effect of the seedling rootstock, as these were budded seedlings (Efron, 1999) and not orthotropic rooted cuttings as those used in the current study.

While location of harvested chupon on stock plant was shown by Efron to affect the height of jorquette, no mention is made of any effect of the nodal position along the chupon regarding jorquette height. In the current study, no effect of chupon location was noted on jorquette height of rooted cuttings (RC-SHW). However, rooted cuttings arising from lower positions (6 - 18) on a chupon jorquetted earlier (and lower) than those from positions 1 -5. Perhaps this is due to the advanced ontogeny of these lower and older materials relative to those nearer the apex. As well, this difference may arise due to a hormonal effect perhaps due to a possible difference in the ratio of auxins and cytokinins.



The current work has basic importance in the area as it is the first study to rigorously document the growth and development of orthotropic clonal cacao from two somatic embryogenesis origins (1°SE and 2°SE), as well as two types of SE-derived rooted cuttings in a comparative manner. It establishes that SE plants grow true to type compared to seedling half sibs. Importantly, orthotropic plants have tap roots or framework roots, which (in contrast to plagiotropic rooted cuttings) may improve tree anchorage besides the potential to assist in drought avoidance when soil moisture levels are reduced. The orthotropic clones grown in this study started in the juvenile phase and transitioned normally to mature phase, forming the characteristic jorquette that begins the canopy formation. This is the same growth as that observed in seedlings, and SEs are also very similar in this respect to seedlings. RC-SW exhibit a slightly delayed phase transition relative to seedlings, but otherwise, are similar in development and growth to seedlings. The decreased growth measurements observed by the 3<sup>rd</sup> harvest in RC-SW occurred due to at least in part to the effect of shading caused by the combination of limited spacing in the experiment and the relatively precocious jorquette development in the other treatments.

RC-SHW have an accelerated phase transition that results in an earlier and lower jorquette along the trunk. A low jorquette may be advantageous in a new planting in regards to facilitating the quick closure of a canopy that may inhibit weed growth, therefore reducing the need for periodical labor-intensive weeding. Additionally, a low jorquette should facilitate harvest and periodic sanitation, reduce the necessity for formative shape pruning, as well as ease monitoring and treating against pests and diseases.

## CHAPTER 4

### STABLE TRANSFORMATION OF *THEOBROMA CACAO* L. AND INFLUENCE OF MATRIX ATTACHMENT REGIONS ON GFP EXPRESSION\*

S. Maximova · C.R. Miller · G. Antúnez de Mayolo · S. Pishak · A. Young · M. J.

Guiltinan

\*This chapter was previously published in *Plant Cell Report*, 2003, 21:872–883 and is reprinted with permission from the publisher. It has been reformatted by the author whose contributions may be found in the following sections: Abstract; Introduction; Materials and Methods, Plant Acclimation, Growth Measurements, Pollination Method and Gene Segregation Analysis, GFP Visualization; Results and Discussion, Transgenic Plant Conversion, Growth, and Gene Segregation Analysis, Growth and Maturation of Transgenic Plants, Transmission of GFP Expression through Sexual Reproduction, and Stability of GFP Expression Level. More specifically, I carried out the greenhouse growth experiment, the production of fruit from pollinations that produced T1 seeds that were grown out, as well as monitored the stability of GFP expression in mature transgenic SE and T1 plants. The data I was responsible for gathering is presented in Table 4.2 and Figure 4.4 as well as the goodness-of-fit  $\chi^2$ .

Received: 7 October 2002 / Revised: 11 January 2003 / Accepted: 14 January 2003 /  
Published online: 3 April 2003\_ Springer-Verlag 2003.

<http://www.springerlink.com/content/c5jptyc6hkgej0wf/fulltext.pdf>

## Abstract

We describe a protocol for *Agrobacterium*-mediated genetic transformation of *Theobroma cacao* L. using cotyledonary explants from primary somatic embryos (SEs) and *A. tumefaciens* strain AGL1. Transgenic plants carrying the visible marker, gene green fluorescent protein (EGFP), the selectable marker gene neomycin phosphotransferase II (NPTII), the class I chitinase gene from cacao (Chi), and tobacco nuclear matrix attachment regions (MARs) in different combinations were successfully produced via regeneration of secondary SEs. The presence of the Chi gene or MARs did not influence the number of transgenic plants produced compared to the marker genes alone. However, the inclusion of MARs contributed to increased mean GFP expression in the population of transgenics. Additionally, the presence of MARs reduced the occurrence of gene silencing and stabilized high levels of GFP expression in lines of transgenic plants multiplied via reiterative somatic embryogenesis. Ninety-four transgenic plants were acclimated in a greenhouse and grown to maturity. Detailed growth analysis indicated that there were no differences in various growth parameters between transgenic and nontransgenic SE-derived plants. Seeds produced from two genetic crosses with one of the transgenic lines were analyzed for EGFP expression—a near-perfect 1:1 segregation was observed, indicating that this line resulted from the insertion of a single locus of T-DNA.

**Keywords:** *Theobroma cacao*, *Agrobacterium tumefaciens*, Genetic transformation, Matrix attachment region, Somatic embryogenesis.

## Introduction

*Theobroma cacao*, a tropical perennial tree species, was originally prized by the ancient meso Americans as an ingredient in ritual drinks (Hurst *et al.*, 2002). The processed form of cacao seeds, cocoa, is now the basis of a multi-billion dollar chocolate industry (Wood and Lass, 1987). Recently, the international agricultural research and development communities have recognized the benefits of cacao farms as ecologically beneficial agroecosystems and thus have begun to promote the sustainable production of cocoa as a means of environmentally friendly poverty amelioration (<http://www.treecrops.org>).

Cacao production suffers from a number of serious plant pests and diseases, which annually reduce the potential yields by as much as 40% (McGregor, 1981; Fulton, 1989). While traditional approaches to reduce pest and pathogen pressure are used in cacao, the high costs, difficulty of chemical application, and remoteness of most of the plantings severely limit their use. Strong genetic resistance in the cacao genome against most of these pests and pathogens has not been identified in primary germplasm. Partial resistance or tolerance has been identified and deployed in some breeding programs over the past century (Eskes and Lanaud, 1997). However, to date, cacao breeding programs, which suffer from a long life cycle, funding constraints, and other limitations, have made limited progress with respect to the incorporation of durable, horizontal resistance to cacao pests and diseases into widely used cacao germplasm.

Modern biotechnology offers an array of approaches to enhance traditional plant breeding programs. Chief among these are plant tissue culture, molecular marker assisted selection (MAS), and genetic transformation (Eskes and Lanaud, 1997; Wilkinson, 2000).

Tissue culture can be a rapid system for clonal propagation of elite germplasm, while MAS can potentially speed up and reduce the costs of breeding programs. However, the plant breeder will still be limited by the genes and sources of resistance that are in the genomes of a species and its close relatives. Genetic transformation, on the other hand, opens an avenue for incorporating novel sources of resistance, or other added value traits, into the genome, which can subsequently be utilized in breeding programs along with endogenous traits (Hansen and Wright, 1999; Persley, 2000). Additionally, genetic transformation provides a very powerful research tool, an invaluable approach for the analysis of gene structure and function that has revolutionized the field of plant molecular biology (Hansen and Wright, 1999). While this approach has been utilized for many plant species and has resulted in a new sector of the agricultural economy, consumer resistance has slowed its application and development in many areas.

To date, only one publication on cacao transformation has been published, and only transformed callus cells were produced from this study (Sain *et al.*, 1994). With an eye towards the future, we report here the development of a genetic transformation system for cacao. Using somatic embryogenesis as a regeneration system, coupled with *Agrobacterium tumefaciens* co-cultivation, transgenic *Theobroma cacao* plants were produced and grown to maturity. Physiological and morphological observations of many of the resulting transgenic cacao plants indicated no detectable pleiotropic phenotypic changes. The inclusion of tobacco matrix attachment regions (MARs) (Allen *et al.*, 1996; Spiker and Thompson, 1996) in the T-DNA did contribute to increased green fluorescent protein (GFP) fluorescence in the primary transgenics and stable and uniform GFP expression among the tertiary somatic embryos produced from the primary transgenics.

Segregation and expression of the transgenes in the subsequent T1 generation indicated stable integration and expression in one of the transgenic lines evaluated.

## Materials and Methods

### *Vector Construction*

Standard gene cloning methods (Ausubel *et al.*, 2001) were used to construct three binary *Agrobacterium tumefaciens* transformation vectors: the primary vector (pGH00.0126), the MARs-containing vector (pGH00.0131), and the chitinase-containing vector (pGAM00.0511) (Figure 4.1). All vectors contained the backbone, left, and right T-DNA borders of the pBin19 transformation vector (Bevan, 1984). The T-DNA region of the primary vector included reporter gene EGFP (Clontech, Palo Alto, CA, U.S.A.) driven by the E12-W promoter (Mitsuhara *et al.*, 1996) and the marker gene neomycin phosphotransferase II (NPTII, De Block *et al.*, 1984), also driven by the E12-W promoter. E12-W is a strong constitutive promoter containing the 50-upstream sequence of the cauliflower mosaic virus (CaMV) 35S promoter (−419 to −90) (twofold); P35S, the 50-upstream sequence of the CaMV 35S promoter (−90 to −1); and W, the 50-untranslated sequence of the tobacco mosaic virus (TMV, Mitsuhara *et al.*, 1996).

Tobacco MARs (Allen *et al.*, 1996; Spiker and Thompson, 1996) flanking the T-DNA were incorporated into the primary vector to create the MARs vector. For construction of the chitinase vector, we digested the primary vector with *Cla*I next to the right T-DNA border and inserted a transgene cassette containing a genomic fragment of the Class I chitinase gene (Chi) isolated from *Theobroma cacao* (accession no. U30324) (Snyder, 1994; Snyder-Leiby and Furtek, 1995). The Chi cassette was constructed with a 1.241-kb

Figure 4.1 Structures of binary transformation vectors for *Agrobacterium tumefaciens*.

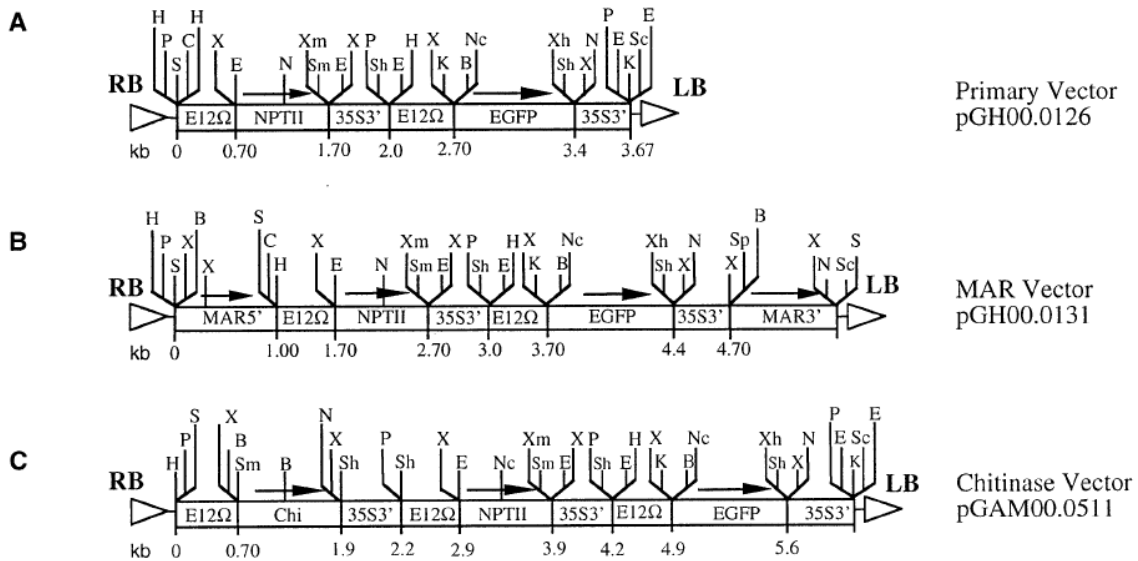

A–C Structures of binary transformation vectors for *Agrobacterium tumefaciens*. All vectors have backbone and left (LB) and right (RB) T-DNA borders from pBin19. A) The primary vector (pGH00.0126) contains a 3.7-kb T-DNA, including an NPTII gene for plant resistance to aminoglycoside antibiotics and EGFP gene encoding for green fluorescent protein. B) The MARs vector (pGH00.0131) contains 50 and 30 tobacco matrix attachment regions (MARs) flanking the NPTII and EGFP genes. C) The chitinase vector (pGAM00.0511) includes NPTII and EGFP gene cassettes with the addition of a cacao chitinase gene (Chi) inserted next to the RB. The E12-W strong constitutive promoter (a CaMV 35S derivative) drives the transgenes in all three vectors. Restriction enzyme recognition sites are indicated at the top of the maps and are abbreviated as follows: B *Bam*HI, C *Cla*I, E *Eco*RI, K *Kpn*I, N *Not*I; Nc *Nco*I, P *Pst*I, S *Sal*I, Sc *Sac*I, Sh *Sph*I, Sm *Sma*I, Sp *Spe*I, X *Xba*I, Xh *Xho*I, Xm *Xma*I. Distance from the left-most site to each restriction enzyme site is indicated below the maps in kilobase pairs (kb) 873.

polymerase chain reaction (PCR) fragment (Ausubel *et al.*, 2001) amplified from position 444 to 1,666 of the genomic chitinase clone. This fragment contains 33 bp of 50 untranslated region, three exons encoding the entire chitinase protein, two introns and 30 bp of 30 untranslated region. To facilitate cloning, restriction fragment recognition sites were added to the ends. The following linkers were used in the PCR reaction: – 50 primer: *Sma*I: 50-ggccccggg (RE site).....cattgacaaaatcacagatatt-30 (chitinase sequence) – 30 primer: *Not*I 50-gggcgggccc (RE site).....gtttaccaaagtttc-30 (chitinase sequence).

The fragment was digested with *Sma*I and *Not*I enzymes and ligated to the intermediate cloning plasmid pE2113-EGFP (cut with *Sma*I and *Not*I to remove the GFP coding sequence). The resulting plasmid, pChi0329, contained the E12-W promoter upstream of the chitinase fragment followed by the 35S terminator. The Chi cassette was excised with *Hind*III, filled in with Klenow and ligated to *Cla*I digested and filled in primary vector, resulting in the chitinase vector. All binary transformation vectors were introduced into the disarmed *A. tumefaciens* strain AGL1 (Lazo *et al.*, 1991) by electroporation (Lin, 1994).

#### *Tissue Culture and Genetic Transformation*

Primary somatic embryos were produced from the greenhouse grown PSU Scavina 6-1 cacao genotype as previously described (Li *et al.*, 1998). Healthy mature primary embryos with developed cotyledons were selected. The cotyledons had glossy surfaces without visible trichomes and an opaque white, pink, or ivory color. The cotyledons were excised and cut into approximately 4 mm<sup>2</sup> pieces for secondary embryogenesis as recently described (Maximova *et al.*, 2002). Prior to culture, the pieces were inoculated with *A. tumefaciens* AGL1 (Lazo *et al.*, 1991) containing one of the three binary vectors. *A. tumefaciens* cultivation, inoculation, and cocultivation with cocoa tissue were performed as previously described for apple (Maximova *et al.*, 1998) with minor modifications, as follows: *A. tumefaciens* was grown in 20 ml of 523 bacterial medium (Dandekar *et al.*, 1989) at 25 C and agitated at 200 rpm on an orbital shaker until the cultures reached an optical density (O.D.) of 1, measured at 420 nm. Bacterial cells were collected by centrifugation (800 g) at 25°C. The pellet was resuspended in induction medium (Maximova *et al.*, 1998) and the O.D. was adjusted to 0.5 at 420 nm. The



induction medium included DKW basal medium, 30 g/l sucrose, 1 g/l glucose, 0.0001 M acetosyringone, and 0.0013 M proline. Virulence was induced for 5 h at 25°C and 100 rpm agitation. After induction, between 100 and 200 cacao cotyledon explants were added to 20 ml of *A. tumefaciens* solution in 50-ml conical tubes. The explants in the *A. tumefaciens* solution were sonicated for 30 s in a Branson water bath (Model 1510, VWR, Pittsburgh, PA, U.S.A.) followed by 10 min of infection at 25°C and 50 rpm agitation. After infection, the *A. tumefaciens* solution was vacuum-aspirated, and the explants were transferred to modified solid SCG medium (Maximova *et al.*, 2002) overlaid with one sheet of Whatman filter paper no. 5 and incubated for 48 h of co-cultivation at 25°C in the dark. Following cocultivation, the explants were transferred to fresh solid SCG medium containing 200 mg/l moxalactam (Sigma-Aldrich, St. Louis, MO, U.S.A.) for *A. tumefaciens* counter-selection and 50 mg/l geneticin (Sigma-Aldrich) for NPTII selection. The infected explants were cultured on geneticin selection for 2 weeks in the dark at 25°C, then transferred and maintained on ED medium (Li *et al.*, 1998) with 200 mg/l moxalactam following the secondary embryogenesis protocol as previously reported (Maximova *et al.*, 2002). Ten different sets of transformation experiments involving three different transformation vectors with 100 to 400 explants infected per experiment were initiated over a period of 12 months. Cultures were observed biweekly, and transgenic embryos were counted. The Fisher Protected LSD test at the  $P < 0.05$  level of significance was used for mean separations (StatView5, SAS Institute, Cary, NC, U.S.A.).

The regenerated transgenic embryos were grown to maturity and their cotyledons excised and cultured for tertiary and quaternary embryo production/multiplication as

described by Maximova *et al.* (2002). Only cotyledons with high GFP fluorescence (measured as described below) were selected for tertiary and quaternary embryogenesis. Mature tertiary somatic embryos (SEs) from 12 transgenic lines (six lines transformed with the primary vector, three lines transformed with the MARs vector, and three lines transformed with the chitinase vector) and three nontransgenic lines were transferred to *in vitro* PEC medium for conversion to plants (Traore, 2000). Between 10 and 54 tertiary embryos—subsequently transferred to conversion medium—were produced per line.

#### *Plant Acclimation*

Three- or four-centimeter-tall, well-developed SE-derived plants with two to six leaves and roots were transferred from *in vitro* culture directly to a climate-controlled greenhouse exceeding NIH PBL2 biosafety conditions. The plants were transplanted to deep pots [6.5 (diameter) x 25 cm] with silica sand for adequate drainage. The acclimation and growth conditions were: 14/10-h (light/dark) photoperiod; 28/25°C (light/dark). For the first 7–10 days, the plants were placed under low light (<100 mmol m<sup>-2</sup>·s<sup>-1</sup> PAR) on a mist bench with approximately 100% humidity; after that, the relative humidity was decreased to 75%. Natural light was supplemented with 430-W high-pressure sodium lamps as needed to maintain a minimum of 250 mmol m<sup>-2</sup>·s<sup>-1</sup> PAR, while automatically retractable shading limited light levels to a maximum of 1,000 mmol m<sup>-2</sup>·s<sup>-1</sup> PAR. Irrigation with 1/10-strength Hoagland's nutrient solution (160 ppm N) was applied daily at multiple times to maintain adequate pot moisture.

Four sets of 10–43 individual transgenic plants from different lines—containing the primary and MARs vectors—and control non-transgenic plants were transferred to the greenhouse. The percentage of acclimated plants was calculated, and the variation

(mean separation) between transformation vectors was analyzed with the Fisher Protected LSD test at  $P < 0.05$  level of significance (StatView5, SAS Institute).

### *Growth Measurements*

A completely randomized design with two treatments (ten transgenic and ten control SE-derived plants) was set up to monitor growth parameters. The transgenic plants evaluated were randomly selected from the first established single transgenic line (T980603) containing the EGFP and NPTII genes. Height, stem diameter, and numbers of leaves were recorded at 5 months after acclimation. To non-destructively estimate whole-plant leaf area, we employed the following approach: leaves of various sizes from both treatments were randomly selected (70 per treatment) and cutouts of their outlines made. The lengths of the cutouts were recorded and their areas measured with a LI-3000A portable area meter (Li-Cor, Lincoln, NE, U.S.A.). Two regression equations—one for transgenic and one for non-transgenic plants—were determined relating leaf length to leaf area. Leaf areas were calculated for individual plant leaves using the regression equations after measuring all leaf lengths from each plant. Total leaf area (in square centimeters) for each plant was then determined by summing the calculated individual leaf areas. Means of the two treatments were calculated and compared using a non-paired, two-tailed t-test (Microsoft Excel, Microsoft, Seattle, WA, U.S.A.).

### *Pollination Method and Gene Segregation Analysis*

Controlled hand-pollinations were performed following standard procedures as described by Wood and Lass (1987). Freshly open flowers from the Pound 7 genotype were fertilized with pollen from 18-month-old transgenic PSU Scavina 6-1. Additionally, flowers from transgenic PSU Scavina 6-1 were fertilized using pollen from the Catongo

genotype. A total of six cacao pods, three per cross, were set and formed seeds. All pods were harvested at 5–6 months after pollination, and EGFP expression/fluorescence in the seed cotyledons was scored under the fluorescent microscope as described below. Chi-square analysis was used to establish the segregation distribution.

### *GFP Visualization*

Bright field and fluorescent images of SEs were taken with a Nikon SMZ-4 dissecting microscope equipped with an epi-fluorescence attachment, a 100-W mercury light source, and a 3 CCD video camera system (Optronics Engineering, Goleta, CA, U.S.A.). The microscope filters used were a 520- to 560-nm emission filter (transmitting only green light) and a 450- to 490-nm excitation filter. The whole plant images were taken with a 3 CCD video camera and 35-mm Nikon lens equipped with a 520- to 560-nm emission filter. The video camera was connected to a Macintosh computer with NIH Image 1.6 image processing and analysis software (Maximova *et al.*, 1998). The GFP fluorescence intensity of different transgenic and non-transgenic cacao tissues was measured under the microscope as previously described in Maximova *et al.* (1998). The fluorescence intensity of cotyledons from etiolated tertiary transgenic SEs from three independent lines per vector (10–12 SEs per line) was measured and compared to that of control non-transgenic SEs. The cotyledons measured were randomly selected from mature SEs and had the same characteristics as explants selected for *A. tumefaciens* transformation (see above). The measurements were taken at a magnification of 30x and an exposure time of 0.5 s. Additionally, young leaves and flowers from 1-year-old transgenic plants (line no. T980603) grown in the greenhouse were observed. Five samples per tissue type per tree were collected from five different transgenic trees and

five control trees. Measurements of fluorescence intensity were taken at a magnification 30x and an exposure time of 1 s. Mean intensities (integrated pixel values, IPV) were measured using NIH Image 1.6 image processing and analysis software (Maximova *et al.*, 1998) and were compared using the Fisher Protected LSD test at  $P < 0.05$  level of significance (StatView5, SAS Institute).

#### *Genomic PCR Analysis*

Three sets of PCR primers were used for the analysis. The first amplifies a 700-bp EGFP fragment (50-CAG ATC TTT ACT TTG ACA GCT CGT CCA TGC CGT-30 and 50-GGG ATC CAT GGT GAG CAA GGG CGA GGA GCT GTT-30) (Maximova *et al.*, 1998); the second produces a 500-bp fragment from the cacao actin gene (50-TGG TGT CAT GGT TGG NATG-30 and 50- GGCACAGTGTGAGANACACC-30); the third set amplifies a 411-bp fragment from the backbone sequence of the pBin19 vector located approximately 2,000 bp upstream of the right T-DNA border in the tetA region (50-CTG GCG GCC GTC TAT GG-30 and 50-CAG CCC CTC AAA TGT CAA-30). Genomic DNA leaf extracts from fully developed transgenic plants from independent lines transformed with the primary vector and with the MARs vector and non-transgenic Scavina 6 plants were prepared using the REDEExtract-N-Amp plant PCR kit (Sigma, St. Louis, MO, U.S.A.). The single-step DNA extraction included incubation of 4-mm leaf disks with 100  $\mu$ l proprietary extraction solution from the PCR kit at 95°C for 10 min, followed by the addition of an equal volume of proprietary dilution solution. Dilutions (1:5) of the extracts were made with water. Four-microliter aliquots of the diluted leaf extracts were added to PCR mix. Each PCR reaction also contained 10  $\mu$ l REDEExtract-N-Amp PCR jumpstart reaction mix and both forward and reverse primers at a final

concentration 0.25  $\mu$ M in a final volume of 20  $\mu$ l. Reactions were prepared at 25°C. Control PCR reactions were also performed with DNA from the primary vector and backbone vector pBin19 containing only the left and right borders without the rest of the T-DNA region (pBin19A), and with the PCR reaction mix without DNA. Plasmid DNA was prepared via dilution series with DNA from salmon sperm (SS) (Sigma-Aldrich no D-1626). A total of 0.15 pg of the respective plasmid DNA was added to each control PCR reaction. This represents an equal molar amount of plasmid DNA compared to the GFP DNA contained in 5 ng total cacao genomic DNA present in the leaf extract, assuming single copy/insertion of the GFP gene. The DNAs added to the control reactions were as follows: SS DNA only; primary vector DNA and SS DNA; primary vector DNA, SS DNA, and Scavina 6 genomic DNA; primary vector DNA, SS DNA and genomic DNA from different transgenic plants. For the plasmid reactions, DNA was isolated using the QIAGEN plasmid midipurification kit (QIAGEN, Valencia, CA, U.S.A.). Reactions were prepared at 25°C as a REDEExtract-N-Amp PCR reaction mix, and primers were added as described above. PCR conditions for all reactions were as follows: 94°C for 2 min; then 35 cycles of 94°C for 45 s, 54°C for 45 s, 72°C for 1 min. The final cycle was followed by incubation at 72°C for 7 min. Eight microliters of each PCR reaction were loaded onto a 2% high-resolution agarose gel (Sigma- Aldrich, no. A-4718) for electrophoresis.

## Results and Discussion

### *Transgenic Embryo Formation and Transformation Efficiency*

Recently, we described a highly efficient system for the regeneration of secondary SEs from primary SE explants originally initiated from floral tissue explants (Maximova *et al.*, 2000, 2002). This system produces more embryos per explant than the primary SE system and, in addition, the embryos have a higher morphological conformity and percentage of conversion to plantlets. We coupled this secondary SE system with *A. tumefaciens* infection and co-cultivation in order to develop a genetic transformation system for *T. cacao*. Another important factor that contributed to the success of this protocol was our recent finding that the antibiotic moxalactam was very effective for *A. tumefaciens* counter-selection and, surprisingly, increased the regeneration frequency of secondary embryos (Anúnez de Mayolo, 2003).

Three binary vectors were constructed based on the Bin19 T-DNA system (Figure 4.1; Bevan, 1984). Each plasmid contained the NPTII and GFP genes under the control of the CaMV 35S promoter derivative E12-W (Mitsuhara *et al.*, 1996). The primary vector contained these two genes alone. The MARs vector contained matrix attachment regions flanking the GFP and NPTII genes. The MAR sequences were previously shown to stabilize levels of gene expression in other transgenic plant systems (Allen *et al.*, 1996). The chitinase vector contained a cacao Chi gene (Snyder, 1994), placed under the control of the same E12-W promoter in addition to the GFP and NPTII genes. The Chi gene was included in a construct as a potential gene for resistance to fungal pathogens.

The binary T-DNA vectors were electroporated into *A. tumefaciens* AGL1, and bacteria were co-cultivated with primary SE cotyledon explants as described above.



Figure 4.2. Green fluorescent protein expression in cacao tissues and plants.

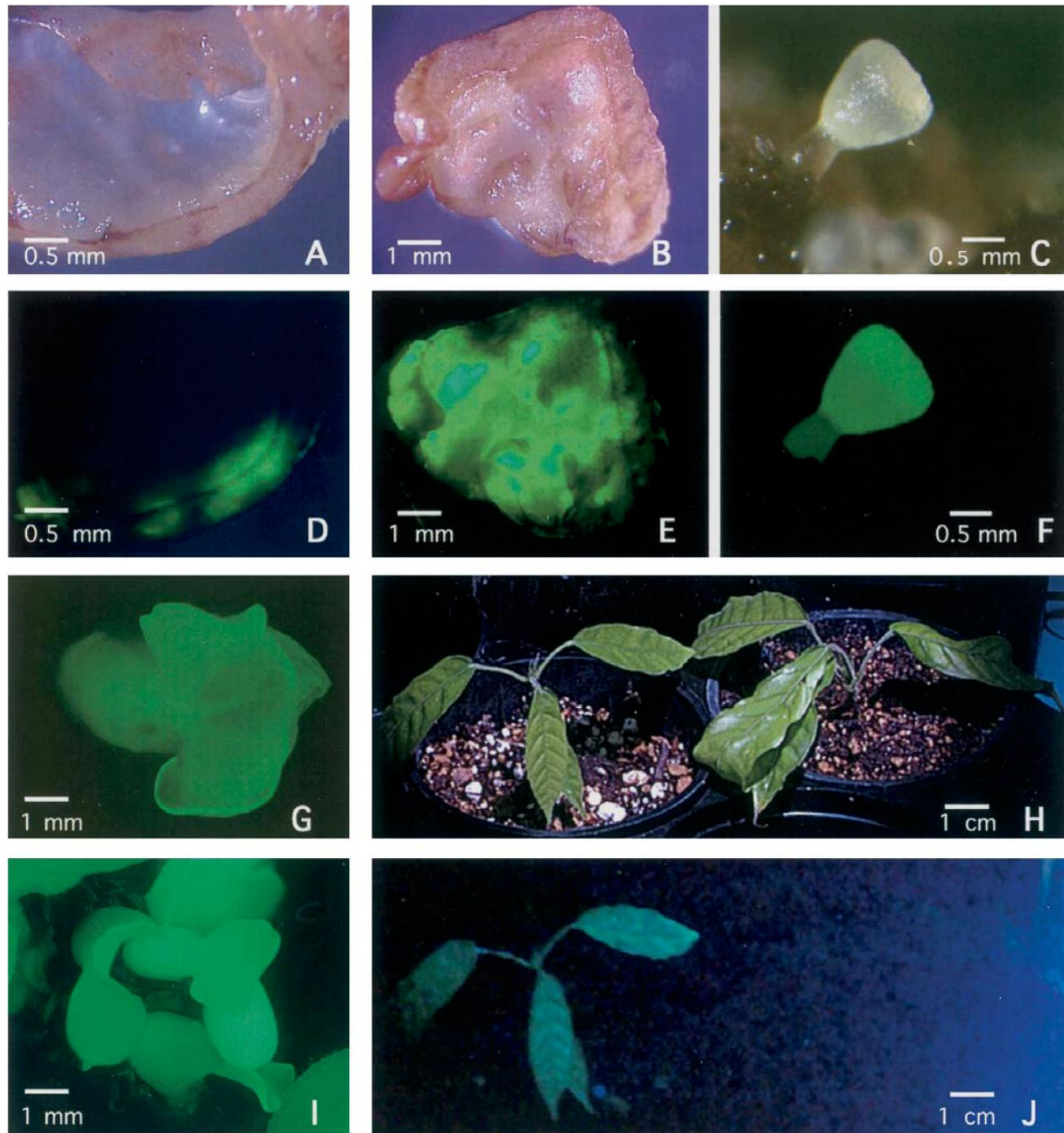

A–J Green fluorescent protein expression in cacao tissues and plants. A–C, H) Light images, D–G, I, J) fluorescent images. A, D) The cut edges of a somatic embryo (SE) cotyledon explant 48 h after *A. tumefaciens* infection. B, E) SE cotyledon explant 10 days after *A. tumefaciens* infection. C, F) Transgenic SE in early-heart stage. G) Mature transgenic SE. H, J) Transgenic and non-transgenic SE-derived plants. I) Tertiary transgenic SEs produced from a cotyledon of the embryo on panel G.

Green fluorescence in the infected explants due to GFP expression was first detected 48 h post *A. tumefaciens* infection (Figure 4.2-A, D). The fluorescence was mainly associated with the cut edges of the explants, as has been observed earlier in other species



(Maximova *et al.*, 1998). During the following 10 days, the fluorescent areas enlarged and their fluorescence intensities increased. Occasionally the fluorescence covered entire explants (Figure 4.2-B, E). The large number of fluorescent areas and the high fluorescence intensity shortly after transformation demonstrated the high frequency of *A. tumefaciens* infection and DNA transfer to the plant cells. However, by 60 days after infection, the fluorescence was reduced to a few small areas, indicating either high transient expression shortly after transformation without gene incorporation or high levels of gene silencing in the cacao genome.

The formation of individual transgenic secondary SEs (TSSE) was observed between 44 days and 180 days after infection (Figure 4.2-C, F). A total of 31 secondary transgenic embryos were regenerated from the ten experiments over a period of one year (July, 2000–August, 2001) (Table 4.1). From these embryos, 14 were transformed with the primary vector, ten with the MARs vector, and seven with the chitinase vector. The mean numbers of transgenic embryos per infected explant produced from the individual transformation experiments were low, ranging from 0 to 0.043 TSSE (Table 4.1). From the seven transformations performed with the primary vector, only one did not generate TSSEs. Similarly only one of the five transformations with pGAM00.0511 did not produce TSSEs. Two of the five transformations carried out with the MARs vector produced TSSEs (Table 4.1). The mean efficiencies (no. of transgenic embryos per infected explant) were calculated for the different vectors, and mean separation indicated no significant differences ( $P=0.61, 0.69, 0.40$ , respectively) (Figure 4.3-A). Compared to the high frequency of transient expression, stable expression frequencies were much lower on a per explant basis. The relatively low production of transgenic embryos was

Table 4.1. Transgenic secondary (TSSE) and tertiary embryos (TTSE) produced from ten *Agrobacterium tumefaciens*-mediated transformation experiments with three different binary vectors.

Experiment ID	Transformation vector	Total no. explants infected	TSSE	Mean no. TSSE per explant	Number of transgenic lines	TTSE
1	Primary	161	4	0.025	4	35
2	Primary	250	1	0.004	0	0
3	Primary	113	0	0.000	0	0
4	Primary	200	3	0.015	1	25
5	Primary	642	2	0.003	1	14
6	Primary	705	2	0.003	1	52
7	Primary	127	2	0.016	2	40
1	MARs	155	0	0.000	0	0
2	MARs	185	8	0.043	3	41
3	MARs	91	2	0.022	1	26
7	MARs	129	0	0.000	0	0
9	MARs	109	0	0.000	0	0
4	Chitinase	201	2	0.010	2	10
5	Chitinase	116	0	0.000	0	0
8	Chitinase	235	2	0.009	1	54
9	Chitinase	113	1	0.009	0	0
10	Chitinase	400	2	0.005	1	33

Transgenic secondary (TSSE) and tertiary embryos (TTSE) produced from ten *Agrobacterium tumefaciens*-mediated transformation experiments with three different binary vectors. Somatic embryo cotyledon explants were transformed in ten different experiments with three different transformation vectors over a period of 12 months. Cultures were observed biweekly, and transgenic embryos were counted. The regenerated individual secondary transgenic embryos were grown *in vitro* to the mature embryo stage after which their cotyledons were excised and cultured for tertiary embryo production/multiplication following the protocol for secondary embryogenesis (Maximova *et al.*, 2002).

consistent among all vectors. However, despite the low efficiency of this protocol, we are able for the first time to consistently and reproducibly generate transgenic cacao plants. Future optimizations of the protocol for increasing the T-DNA incorporation efficiency should include evaluation of different vectors, selectable marker and reporter genes, selection conditions, and *A. tumefaciens* strains.

The occurrence of gene silencing is a possible explanation for the low frequency of transgenic embryo regeneration. In other plant species tobacco nuclear MARs have been shown to enhance and stabilize transgene expression after transformation with *A. tumefaciens* and to reduce the frequency of gene silencing (Allen *et al.*, 2000). We reasoned that if the dramatic difference observed between transient and stable expression in cacao was due to gene silencing, the incorporation of MARs could enhance transgenic embryo recovery. To test this hypothesis, we incorporated tobacco MAR sequences

Figure 4.3. Mean number of transgenic embryos produced and plant conversion rates from ten transformation experiments.

**A**

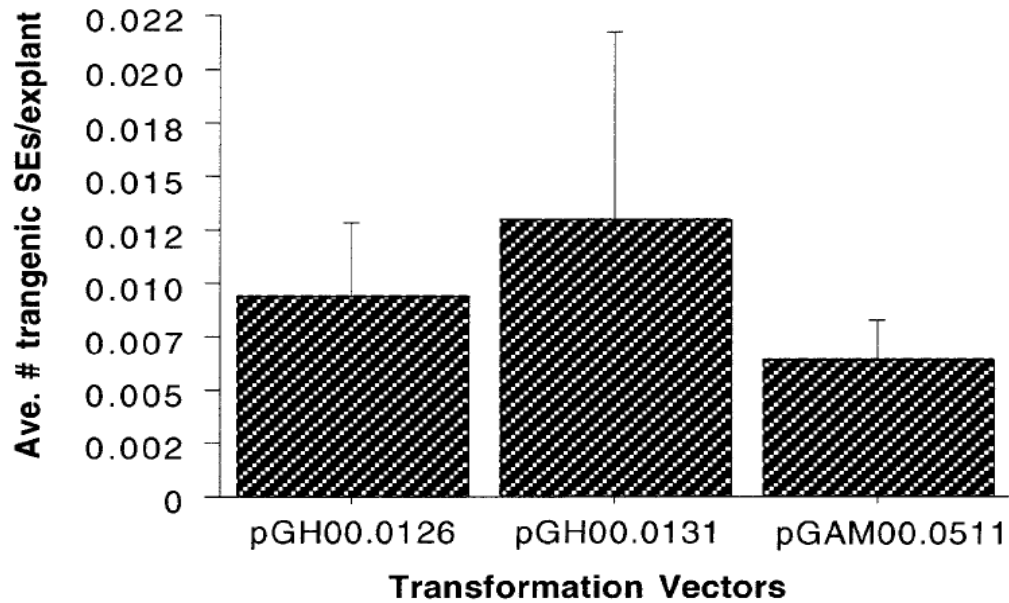

**B**

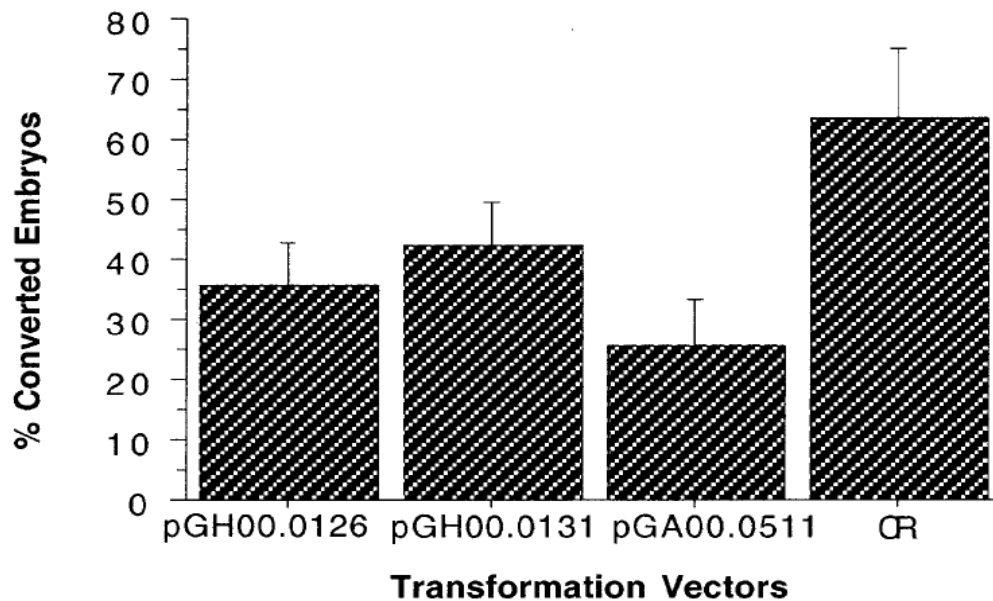

A, B) Mean number of transgenic embryos produced and plant conversion rates from ten transformation experiments. Vector designations are as follows (see Materials and methods for details): p126 the primary vector, p131 the MARs-containing vector, p511 the chitinase-containing vector. The vectors used for transformation were described in Figure 4.1. Mean separation was performed with the Fisher Protected LSD test at  $P < 0.05$  level of significance. A Mean numbers  $\pm$  standard error (SE) of transgenic embryos produced per infected explant, B percentages  $\pm$  SE of mature transgenic and nontransgenic somatic embryos converted to plants.

within the T-DNA of the resulting MARs plasmid. However, after five transformation experiments with this vector, no significant difference in the number of transgenic embryos recovered was observed (Figure 4.3-A). It is possible that any expected positive effect of the MARs was reduced or eliminated due to the slow growing nature of the cotyledon cells involved in embryo regeneration (Allen *et al.*, 2000). Compared to some of the faster plant regeneration systems—for example, like tobacco (Fisher and Guiltinan, 1995), which requires only 20 days to produce regenerants—cacao cotyledon tissue regenerates slowly and takes 60–200 days to produce the first SEs. Alternative possible explanations are that the low stable transformation frequency is due to trans silencing mediated by sequence homology somewhere else in the cacao genome, against which the presence of MARs is ineffective, or that the MARs effect was decreased by the cis interactions among the repeated sequences of the E12-W promoter (Allen *et al.*, 2000). Considering the possibility of promoter homology-dependant silencing, we should note that the incorporation of Chi as the third transgene driven by the E12-W promoter without the presence of MARs did not result in a lower transgenic embryo production. However, in view of the general low regeneration frequency of the system, additional experiments, including larger number of samples and transgenic lines, are needed to substantiate this observation.

In order to clonally propagate independent transgenic somatic embryo lines, we initiated tertiary somatic embryogenesis. Cotyledon explants from mature T0 transgenic embryos were cultured for multiplication and the establishment of transgenic lines by the re-initiation of somatic embryogenesis on embryo induction medium. A total of 16 transgenic lines were established, each of which produced between 10 and 52 individual

tertiary transgenic SEs. Nine of these lines originated from T0 transformations containing T-DNA from the primary vector, four from the MARs vector, and three from the chitinase vector (Table 4.1). The successful multiplication of the single T0 regenerants was an important step of the protocol for the establishment of transgenic lines for further transgene expression and growth analysis. Considering the relatively low transgenic embryo regeneration (T0) frequency and the 50–60% embryo-to-plant conversion rates (Figure 4.3-B) in this system, the high rates of tertiary embryo production is an important attribute of this system for obtaining sufficient transgenic plants for subsequent analysis.

#### *Transgenic Plant Conversion, Growth, and Gene Segregation Analysis*

Conversion of *in vitro* somatic embryos into functional autotrophic plants (conversion) is an essential and sometimes difficult process for some species. Furthermore, it is possible that this process may be sensitive to DNA transformation and/or transgene expression. Between 10 and 54 transgenic embryos from different transgenic cacao lines were converted to plants *in vitro*, and the effect of different T-DNAs on the conversion rates were evaluated (Figure 4.3-B). The mean percentage of transgenic SEs containing T-DNA from the primary and chitinase vectors that converted to plants (35.8% and 25.7%, respectively) was significantly lower than the percentage of control non-transgenic secondary embryos converted (63.5%,  $P=0.031$ ,  $P=0.016$ , respectively). No significant difference between control SEs and SEs transformed with the MARs vector (41.9%,  $P=0.135$ ) was observed. However, at the same significance level (5%), no differences were measured between the two other vectors and the MARs vector ( $P=0.628$ ,  $P=0.279$ , respectively). Hence, the slightly higher conversion rates of plants transformed with the MARs vector could be due to the inclusion of the MARs

sequences or, alternatively, the difference could be a result of positional effects of the insertions recovered in this study.

### *Growth and Maturation of Transgenic Plants*

To test the possible effects of transgene insertion on the growth and physiology of the transgenic cacao plants, we carefully compared control and transgenic plants for morphological characters. Ten plants from transgenic line T980603 containing the EGFP and NPTII genes and ten control SE-derived plants were grown to maturity in a greenhouse. All stages of development of these plants exhibited GFP expression as observed by fluorescence imaging (data not shown). At 5 months after acclimation, plant height, stem diameter, and the number and surface area of all leaves were recorded. Both sets of plants grew at similar rates (Table 4.2). No significant differences in their height, stem diameter, and leaf area were observed, indicating that the transformation process and expression of the transgenes in this line did not result in any visible phenotypic alterations. Additionally, 94 newly converted and acclimated plants from ten independent transgenic lines were observed in the greenhouse for a period of 3–4 months and these also did not demonstrate any visible phenotypic alterations (data not shown).

Table 4.2. Comparison of the growth parameters of transgenic and control somatic embryo (SE)-derived plants after 5 months in the greenhouse.

Treatment	Plant height (cm)	Stem diameter (cm)	Numbers of leaves	Leaf area (cm <sup>2</sup> )
Transgenic	89.0±4.3	1.23±0.04	54.0±2.9	5,340±480
Control	95.2±4.9	1.25±0.06	59.2±3.7	6,400±540
<i>P</i> value	0.35	0.79	0.29	0.16

Comparison of the growth parameters of transgenic and control somatic embryo (SE)-derived plants after 5 months in the greenhouse. The growth to maturity of ten transgenic and ten control SE-derived plants was monitored. The transgenic plants evaluated were from a single line containing the EGFP and NPTII genes. Data were recorded at 5 months after acclimation. Each value is a mean  $\pm$  standard deviation of ten repetitions. *P* values greater than 0.05 are non-significant as determined by a non-paired, two-tailed t-test (Microsoft Excel).

### *Transmission of GFP Expression through Sexual Reproduction*

After both set of plants had developed flowers, two crosses were performed: transgenic T980603 (female) x Catongo (male) and Pound 7 (female) x transgenic T980603 (male). Six cacao pods were produced with a total of 282 T1 seeds (44–50 seeds per pod). All maternal tissue in the cacao pods produced from the first cross exhibited high levels of GFP expression, including the pod surface, exocarp, placental tissues, and seed coats. Segregation of GFP expression was clearly observed after removal of the seed coats, and very high levels of GFP accumulation occurred in the cotyledons and embryos of the transgenic seeds. From all the crosses, 143 seeds scored positive and 139 negative for GFP expression in the cotyledons. The goodness-of-fit Chi-square ( $\chi^2$ ) for a 1:1 distribution demonstrated that the GFP gene in the T1 generation of line T980603 segregated as a single locus insertion ( $\chi^2=0.422$ , 3 df). All seeds were germinated and grown in the greenhouse. Leaf and root samples from all of the seedlings were observed for EGFP expression at 6 months after germination. All of the originally GFPpositive seeds produced plantlets expressing GFP, indicating stability of the EGFP transgene expression through meiosis, fertilization and into the T1 progeny.

### *Stability of GFP Expression Level*

In order to assess the stability and variation in GFP expression in different transgenic lines, and to evaluate the influence of the MARs in further detail, we measured GFP expression *in vivo* using semi-quantitative fluorescence microscopy. The fluorescent intensity (represented as IVPs) of etiolated SE cotyledons due to expression of the GFP gene was measured in transgenic SEs and compared to background fluorescence in non-transgenic SEs. The values recorded for highly fluorescent cotyledons of transgenic SEs were up to 17.7-fold higher than the background fluorescence levels found in non-transgenic SEs ( $P < 0.0001$ ) (Figure 4.4-A). The variation among the fluorescence intensities of SE lines was assessed in three different ways: among lines transformed with different vectors, among lines transformed with the same vector, and variation among multiple SEs regenerated from individual lines.

We observed that despite the high green fluorescence/ GFP expression of all transgenics (T0) selected for multiplication via tertiary embryogenesis, the new embryos that were produced were not always fluorescing. Complete silencing (no green fluorescence) was observed in two lines from a total of eight lines established containing the primary vector and in one line from a total of four lines established with the chitinase vector. In contrast, all four lines containing the MARs vector were highly fluorescent (Figure 4.4-A). The overall expression levels ( $\pm$ standard error) (IVPs) recorded were:  $103.06 \pm 20.45$ ,  $226.49 \pm 4.42$ , and  $98.89 \pm 81.29$  for the primary, MARs and, chitinase vectors respectively. The fluorescence intensity of non-transgenic SEs was  $14.47 \pm 0.03$  IVPs. The overall mean intensities of the lines transformed with the primary and chitinase vectors were significantly lower than that of the MARs vector ( $P < 0.0001$ ). Additionally,



Figure 4.4. Evaluation of green fluorescent protein fluorescence of control and transgenic tissues from multiple somatic embryo lines and mature cacao plants.

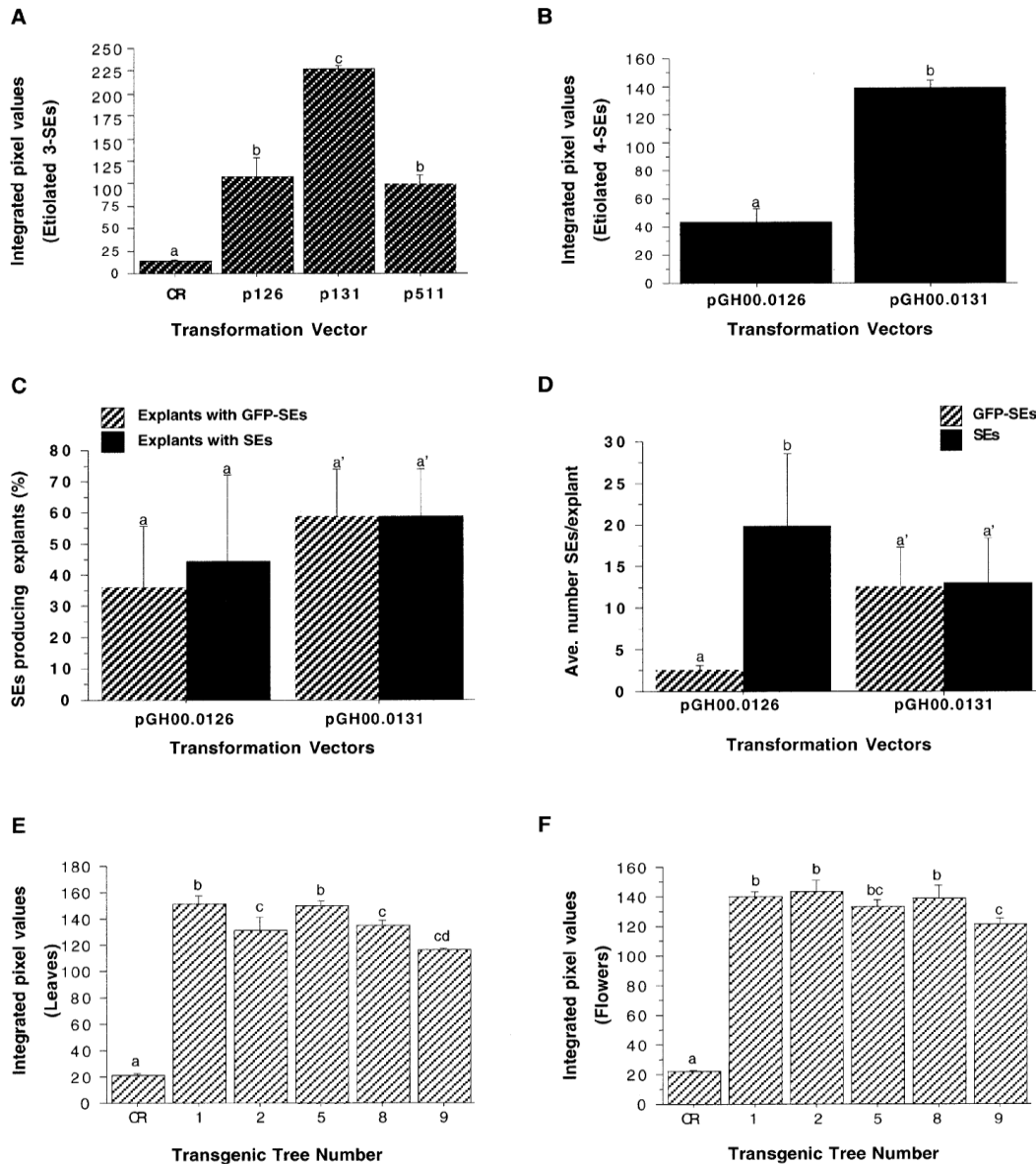

A–F Evaluation of green fluorescent protein fluorescence of control and transgenic tissues from multiple somatic embryo lines and mature cacao plants. Vector designations are as follows (see Materials and Methods for details): p126 the primary vector, p131 the MARs containing vector, p511 the chitinase-containing vector. Fluorescence intensity was expressed as integrated pixel values (IPVs). A IPVs of tertiary control and transgenic etiolated SEs regenerated in the dark. B IPVs of transgenic, quaternary etiolated SEs regenerated in the dark. C Percentages  $\pm$  SE of tertiary, transgenic cotyledons producing at least one quaternary somatic embryo and producing at least one fluorescent somatic embryo. D Average numbers  $\pm$  SE of quaternary somatic embryos per producing cotyledon and average number  $\pm$  SE of fluorescent quaternary somatic embryos per producing cotyledon. E Mean IPV  $\pm$  SE of control and transgenic leaves. F Mean IPV  $\pm$  SE of control and transgenic flowers. The mature plants measured for E and F were from a single line (T980603) containing the EGFP and NPTII genes without MARs. Mean separations were performed with the Fisher Protected LSD test at  $P < 0.05$  level of significance. Means marked with different letters are significantly different from each other.

the lines transformed with the primary and chitinase vectors were not significantly different from each other ( $P=0.7508$ ). All of the transgenic SEs lines were significantly different from the controls ( $P<0.003$ ). On the basis of the overall intensity data and the data recorded for the mean intensities of individual lines (Figure 4.4-A, Table 4.3), it appears that the presence of the MARs may have contributed to higher mean expression levels. Similar observations of a correlation between increased mean transgene expression levels of populations of transformants and MARs-containing transgene constructions have been reported for other plant species (Allen *et al.*, 2000).

Table 4.3. Mean values of green fluorescent protein fluorescence intensity  $\pm$  standard error and their variances.

Line no.	Transformation vector	Mean intensity	Standard error	Variance
1	Primary	42.34	13.91	1354.86
2	Primary	14.44	0.02	0.03
3	Primary	209.38	12.21	1340.57
1	Chitinase	80.14	13.25	5442.12
2	Chitinase	190.32	7.83	736.30
3	Chitinase	62.04	19.40	5273.28
1	MARs	223.44	6.47	419.04
2	MARs	225.18	8.49	576.75
3	MARs	237.26	7.41	219.53
1	CR <sup>b</sup>	14.53	0.13	0.02
2	CR	14.43	0.07	0.01
3	CR	14.44	0.07	0.01

Mean values of green fluorescent protein fluorescence intensity  $\pm$  standard error and their variances. Fluorescence intensity of cotyledons from etiolated tertiary transgenic SEs from three independent lines per vector (10–12 SEs per line) was measured and compared to that of control non-transgenic SEs. Fluorescent images were taken with a Nikon SMZ-4 dissecting microscope equipped with an epifluorescence attachment, a 100-W mercury light source and a 3 CCD video camera system (Optronics Engineering). The microscope filters used were a 520–560 nm emission filter and a 450–490 nm excitation filter. Mean intensities (integrated pixel values) were recorded using NIH Image 1.6 image processing and analysis software (Maximova *et al.*, 1998) b Control regeneration.

Additional comparisons among the mean intensities of three individual lines per transformation vector supported this observation (Table 4.3). The largest differences were

recorded among the lines containing the primary and chitinase vectors. In contrast, no differences were recorded among the lines with the MARs vector.

To establish the variation within the individual transgenic lines, we compared the standard errors and variances of the lines (Table 4.3). These data demonstrated that the standard errors and variances of the transgenic lines containing MARs are significantly lower, suggesting that the presence of the MARs sequences contributed to stable, high expression levels within the individual lines of tertiary embryos. To our knowledge, this is the first report of a positive MARs influence on gene silencing during somatic embryogenesis and regeneration of clones from a single transgenic plant. The differences in GFP fluorescence within a single primary vector line are demonstrated in Figure 4.5. The brightness of the fluorescence varied from very high to very low.

To further evaluate the influence of MARs on somatic embryogenesis, highly fluorescent cotyledons from tertiary SEs containing the primary vector and MARs vector were cultured and regenerated. Explants were selected from three different lines per vector. At 60 days after culture initiation, the fluorescence intensities (IPVs) of quaternary randomly selected embryos were measured (30 SEs x three lines x two vectors) (Figure 4.4-B). The results from the separation of the mean IPVs for the two vectors were similar to those previously obtained for tertiary SEs. The mean fluorescence of the embryos containing MARs was significantly higher ( $P < 0.0001$ ) than those without MARs (Figure 4.4-B). A comparison of the percentage of explants producing one or more SEs to the percentage of explants producing one or more fluorescent SEs (GFPSEs) demonstrated that all of the SE-producing explants containing the MARs vector were also producing GFPSEs (Figure 4.4-C). In contrast, 25% of the cotyledons of one of the

Figure 4.5. Microscope images of the variation in green fluorescent protein (GFP) fluorescence intensity among different tertiary SEs from a single transgenic line containing the primary vector pGH00.0216.

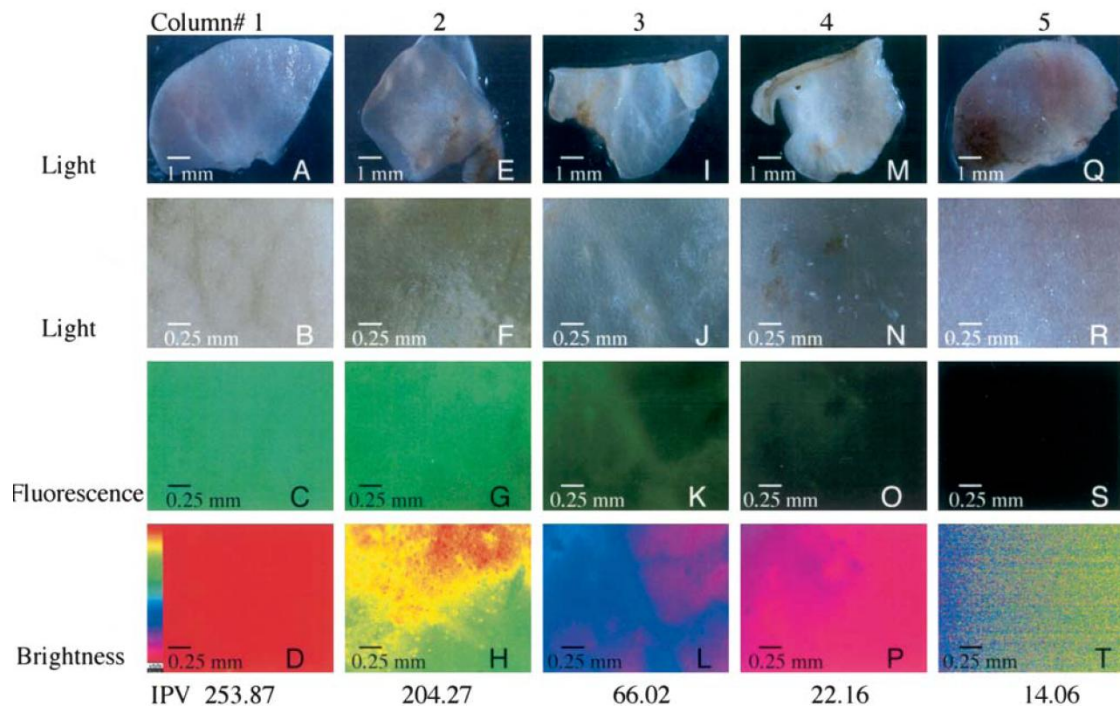

A–T Microscope images of the variation in green fluorescent protein (GFP) fluorescence intensity among different tertiary SEs from a single transgenic line containing the primary vector pGH00.0216. Rows 1, 2 Light images, row 3 fluorescent images, row 4 color-coded brightness of GFP fluorescence—the brightness scale is from red to purple, with red representing the brightest fluorescence and purple representing the lowest fluorescence. Each column contains images of one of the five explants selected from different somatic embryos. A–D Transgenic explant no. 1, E–H transgenic explant no. 2, I–L transgenic explant no. 3, M–P transgenic explant no. 4, Q–T control non-transgenic explant. Rows 3, 4, 5 are magnified images of the explants in row 1. The measurements of GFP brightness were taken at high magnification to ensure a uniform and flat surface. IPV Integrated pixel value 881.

primary vector lines produced only silenced SEs. No statistical differences between the percentages of SE and GFP-SE cotyledons were recorded within the individual vectors ( $P=0.818, 0$ ) (Figure 4.4-C). Further analysis of the average numbers of GFP-SEs per producing explant established that the majority of SEs regenerated from the primary vector lines were silenced and that close to 100% of the SEs regenerated from the MARs vector lines were highly fluorescent (Figure 4.4-D). These results provide additional

evidence of the preventive effect of MARs on transgene silencing during cacao somatic embryogenesis.

Variation in GFP levels was also investigated in leaves and flowers removed from mature trees, which were clonal replicates of the same line (T980603) (Figure 4.4-E, F). Minor variation was observed among the values recorded for individual trees for both leaves and flowers (Figure 4.4-E, F), with differences of between 1.15- and 1.3-fold for the leaves and 1.15- and 1.57-fold for the flowers. The lower intensity values for leaves and flowers compared to etiolated SEs could be attributed to the partial absorption of the fluorescence by the pigments in these tissues.

#### *Molecular Analysis of Transgene Insertion into the Genome*

The incorporation of the EGFP gene was verified by genomic PCR (Figure 4.6). As a result of using specific PCR primers, our strategy allows the detection of T-DNA insertion, while also demonstrating the lack of non-T-DNA region sequences of the binary plasmid. This allows us to rule out the possibility of *A. tumefaciens* contamination contributing to GFP expression or to the amplification of T-DNA region sequences. As a positive control for the amplification of the non-T-DNA region, (binary PCR test), we used a cacao actin gene sequence. The three primer sets were multiplexed to allow amplification in one tube and the display of each line in a single electrophoretic lane. This strategy enables the molecular verification of transgene insertion into genomic DNA using very small amounts of tissue, thus facilitating the early analysis of the SE lines. Furthermore, this protocol requires one simple and easy DNA extraction step without purification (see Materials and methods).

Figure 4.6. Genomic PCR analysis of non-transgenic and transgenic lines containing the EGFP gene.

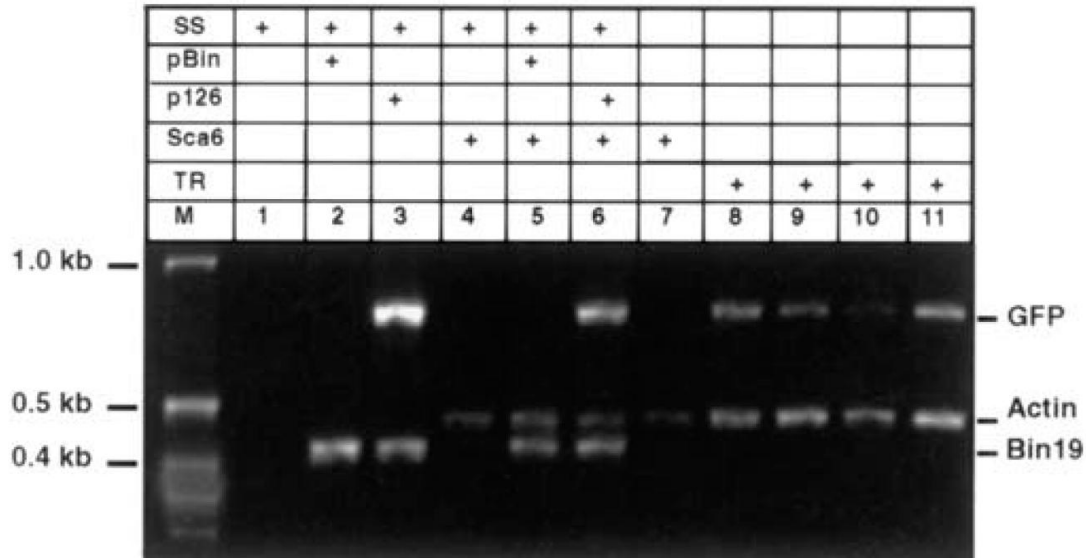

Genomic PCR analysis of non-transgenic and transgenic lines containing the EGFP gene. PCR amplification was performed with three primer sets: pBin19 backbone primers amplifying a 400-bp fragment, cacao actin gene primers producing a 500-bp fragment, and EGFP gene primers amplifying a 700-bp fragment. The control plasmid DNAs used were Bin19A DNA (pBinA), containing only left and right borders without the rest of the T-DNA region, and the primary vector pGH00.0126 DNA (p126), including the EGFP gene. The plasmid DNA was diluted to 0.15 pg in salmon sperm DNA (SS). Leaf extract from non-transgenic Scavina 6 (Sca6) and transgenic plants (TR) from four independent lines were prepared using the REExtract-N-Amp plant PCR kit (Sigma) and used for cacao genomic DNA analysis.

A series of dilution and mixing controls were performed to demonstrate the specificity and sensitivity of the procedure. Plasmid DNAs containing the binary plasmids used in this study were diluted to genome equivalent amounts (15 pg of plasmid equals approximately molar-equivalent to 5 ng of cacao genomic DNA) using ssDNA as carrier (5 ng per reaction). No amplification was observed with all three of the primer sets and the ssDNA used to dilute the plasmid DNAs (Figure 4.6, lane 1). The PCR of vector pBin19A (no GFP gene) resulted only in the amplification of one 411-bp fragment corresponding to the pBin19 backbone fragment (Figure 4.6, lane 2). As expected, the primary vector produced two fragments: a 411-bp pBin19 backbone fragment and a 700-bp EGFP fragment (Figure 4.6, lane 3). The mixture of equal amounts non-transgenic



Scavina 6 DNA and ssDNA produced only the expected 500-bp cacao actin fragment (Figure 4.6, lane 4). The combination of pBin19A with non-transgenic Scavina 6 resulted in amplification of the 411-bp pBin19 backbone fragment and the 500-bp cacao actin fragment (Figure 4.6, lane 5). When pBin19A was substituted with the primary vector (containing the GFP gene), an additional 700-bp EGFP fragment was observed (Figure 4.6, lane 6). No EGFP gene or pBin19 backbone fragment amplification was observed using the nontransgenic SE DNA template in the reaction (Figure 4.6, lane 7). This reaction produced only the expected 500-bp cacao actin fragment. All of the transgenic lines evaluated produced a 500-bp cacao actin fragment and the 700-bp EGFP fragment. Representative of these data, reaction products from two lines with the primary vector and two with the MARs vector are presented in Figure 4.6 (lanes 8– 11). These results demonstrate that the EGFP gene was stably incorporated into the genomes of these plants and that the amplification was not due to *A. tumefaciens* contamination. Additionally, we confirmed that the PCR method described in this study provides a fast and reliable means for screening for transgenic plants with minimal DNA extraction step.

The study presented here demonstrates that using cocultivation of SEs with *A. tumefaciens* led to the recovery of stably transformed cacao plants in ten consecutive experiments. The number of T0 plants regenerated per explant was relatively low, but the consistency of the regeneration, the high efficiency of tertiary embryogenesis, and the reasonable conversion rates provide a working protocol for cacao transformation. Because of the low frequency of transgenic embryos recovered, the use of EGFP was of major importance for the non-lethal identification of transgenic embryos at early stages of development. The use of the GFP marker gene enabled the optimization of many

variables in this protocol quickly. Further improvement in transformation efficiency would be necessary to allow the elimination of the GFP gene for generation of transgenic plants. Alternatively, other methods for gene removal following transformation may be utilized for cacao (Hare and Chua, 2002). The transgenes incorporated into these plants did not interfere with the regeneration or growth of the plants, and they were stably integrated and expressed into the next generation of progeny of one line. The incorporation of MARs appears to be important for stabilizing transgene expression during somatic embryogenesis and transgenic line establishment. Future experiments incorporating genes of interest into the MAR vectors would further establish the reliability of the system. This system can be used as a basis for analyzing gene structure and function in cacao, and as a model system for testing the effectiveness of transgenes for enhancement of desired traits in cacao, such as fungal or viral disease resistance.

#### *Acknowledgements*

We would like to thank Dr. Steven Spiker for providing the tobacco MARs sequences and DNA, J.D. Swanson for providing the cacao actin gene PCR primers and Maureen Clancy, and Shelby Latchford for their technical assistance. This work was supported in part by The Pennsylvania State University, College of Agricultural Sciences (CRIS 3550).

#### References

- Allen, G.C. Hall, G., Michalowski, S., Newman, W., Spiker, S., Weissinger, A.K., Thompson, W.F. 1996. High-level transgene expression in plant cells: effects of a strong scaffold attachment region from tobacco. *Plant Cell*, 8:899–913.



- Allen, G.C., Spiker, S., Thompson, W.F. 2000. Use of matrix attachment regions (MARs) to minimize transgene silencing. *Plant Molecular Biology*, 43:361–376.
- Antúnez de Mayolo, G., Maximova, S.N., Pishak, S., Gultinan, M.J. 2003. Moxalactam as a counter-selection antibiotic for *Agrobacterium*-mediated transformation and its positive effects on *Theobroma cacao* somatic embryogenesis. *Plant Science*, 164: 607-615.
- Ausubel, F.M., Brent, R., Kingston, R.E., Moore, D.D., Seidman, J.G., Smith, J.A., Struhl, K. 2001. *Current protocols in molecular biology*. Wiley, New York
- Bevan, M. 1984. Binary *Agrobacterium* vectors for plant transformation. *Nucleic Acids Research*, 12:8711–8721.
- Dandekar, A.M., McGranahan, G.H., Leslie, C.A., Uratsu, S.L. 1989. *Agrobacterium*-mediated transformation of somatic embryos as a method for the production of transgenic plants. *Journal Tissue Culture Methods*, 12:145–149.
- De Block, M., Herrerra-Estrella, L., Van Montagu, M, Shell, J., Zambryski, P. 1984. Expression of foreign genes in regenerated plants and their progeny. *The EMBO Journal*, 3:1681–1689.
- Eskes, A., Lanaud, C. 1997. Cocoa. In: Charrier, A., Jacquot, M., Hamon, S., Nicolas, D. (eds.) *L'Amelioration des plantes tropicales*. CIRAD/ORSTROM, Paris, 623 pp.
- Fisher, D.K., Gultinan, M.J. 1995. Rapid, efficient production of homozygous transgenic tobacco plants with *Agrobacterium tumefaciens*: a seed-to-seed protocol. *Plant Molecular Biology Reporter*, 13:278–289.
- Fulton, R.H. 1989. The cacao disease trilogy: black pod, monilia pod rot, and witches' broom. *Plant Disease Journal*, 73:601–603.

- Hansen, G., Wright, M.S. 1999. Recent advances in the transformation of plants. Trends in Plant Science, 4:226–231.
- Hare, P.D., Chua, N.H. 2002. Excision of selectable marker genes from transgenic plants. Nature Biotechnology, 20:575–580.
- Hurst, W.J., Tarka, S.M., Powis, T.G., Valdez, F., Hester, T.R. 2002. Cacao usage by the earliest Maya civilization. Nature, 418:289–290.
- Lazo, G.R., Stein, P.A., Ludwig, R.A. 1991. A DNA transformation competent *Arabidopsis* genomic library in *Agrobacterium*. Biotechnology, 9:963–967
- Li, Z., Traore, A., Maximova, S., Gultinan, M.J. 1998. Somatic embryogenesis and plant regeneration from floral explants of cacao (*Theobroma cacao* L.) using thidiazuron. In Vitro Cell and Developmental Biology – Plant, 34:293–299.
- Lin, J. 1994. Optimization of the transformation efficiency of *Agrobacterium tumefaciens* cells using electroporation. Plant Science, 101:11–15.
- Maximova, S.N., Dandekar, A.M., Gultinan, M.J. 1998. Investigation of *Agrobacterium*-mediated transformation of apple using green fluorescent protein: high transient expression and low stable transformation suggest that factors other than T-DNA transfer are rate-limiting. Plant Molecular Biology, 37:549–559.
- Maximova, S.N., Alemanno, L., Young, A., Traore, A., Ferriere, N., Gultinan, M.J. 2000. Efficiency, origin and quality of cacao somatic embryogenesis. In: Secretary General, Cocoa Producers' Alliance (ed.) 13th International Cocoa Research Conference Kota Kinabalu, Sabah, Malaysia, 1299–1305.
- Maximova, S.N., Alemanno, L., Young, A., Ferriere, N., Traore, A., Gultinan, M.J. 2002. Efficiency, genotypic variability, and cellular origin of primary and secondary somatic

- embryogenesis of *Theobroma cacao* L. In *In Vitro Cellular and Development Biology – Plant*, 38:252–259.
- McGregor, A. 1981. *Phytophthora* pod rot research in Papua New Guinea since 1971. In: Secretary General, Cocoa Producers' Alliance (ed.) International Cocoa Research Conference Kota Kinabalu, Sabah, Malaysia, pp 339–345
- Mitsuhara, .I, Ugaki, M., Hirochika, H., Ohshima, M., Murakami, T., Gotoh, Y., Katayose, Y., Nakamura, S., Honkura, R., Nishimiya, S., Ueno, K., Mochizuki, A., Tanimoto, H., Tsugawa, H., Otsuki, Y., Ohashi, Y. 1996. Efficient promoter cassettes for enhanced expression of foreign genes in dicotyledonous and monocotyledonous plants. *Plant Cell Physiology*, 37:49–59.
- Persley, G.J. 2000. Agricultural biotechnology and the poor: promethean science. In: Persley GJ, Lantin MM (eds.). *Agricultural biotechnology and the poor*. Consultative Group on International Agricultural Research, Washington, D.C., 3–21.
- Sain, S.L., Oduro, K.K., Furtek, D.B. 1994. Genetic transformation of cocoa leaf cells using *Agrobacterium tumefaciens*. *Plant Cell Tissue and Organ Culture*, 37:342–351.
- Snyder, T. 1994. Isolation and characterization of a genomic chitinase clone from *Theobroma cacao* L. Intercollege Program in Plant Physiology, The Pennsylvania State University, PA.
- Snyder-Leiby, T.E., Furtek, D.B. 1995. A genomic clone (Accession No. U30324) from *Theobroma cacao* L. with high similarity to plant class I endochitinase sequences. *Plant Physiology*, 109: 338.
- Spiker, S., Thompson, W.F. 1996. Nuclear matrix attachment regions and transgene expression in plants. *Plant Physiology*, 110:15–21.

Traore, A. 2000. Somatic embryogenesis, embryo conversion, micropropagation and factors affecting genetic transformation of *Theobroma cacao* L. Food Science, The Pennsylvania State University, PA.

Wilkinson, M.J. 2000. The application and constrains of new technologies in plant breeding. In: Eskes A (ed.). International Workshop on New Technologies on Cocoa Breeding. INGENIC, Kota Kinabalu, Sabah, Malaysia, 12–24.

Wood, G.A.R., Lass, R.A. 1987. Cocoa. Longman/Wiley, New York. 883 pp.

## CHAPTER 5

### CONCLUSIONS AND FURTHER RESEARCH

*“Many people tell us a great deal about ‘tap-root’. Personally I have no reverence whatever for even the name of ‘tap-root’ but at the same time- I have every respect for the principle which has led to the great respect paid to the ‘tap-root’, by the greater number of West Indian planters; and this principle is, that even the slightest damage cannot occur to any root without loss to the plant with which it is concerned.”*  
-J.H. Hart (1900)

Somatic embryogenesis allows for the clonal propagation from floral parts cultured *in vitro* of true to type cacao trees with tree architecture of a seminal plant. As well, greenhouse vegetative propagation techniques produce rooted cuttings with tree architecture of a seminal plant. By incorporating upstream *in vitro* technologies with downstream traditional plant propagation, greater efficiencies in a vegetative production system in cacao may be achieved. The main objective of the current research was towards the further development and characterization of an integrated *in vitro* and greenhouse vegetative orthotropic propagation system in cacao, with particular emphasis on the downstream greenhouse aspects. This process allows for the most rapid utilization of vegetative materials, in this case orthotropic, for further mass clonal multiplication and bulking up of plant materials for distribution.

To this end, acclimated SE plants at the softwood stage were established and maintained as orthotropic stock plants in a climate controlled greenhouse, from which chupons were harvested repeatedly for rooting of stem cuttings. As well, one-year-old 2°SE trees at the semi-hardwood stage were bent to horizontal to promote the release of

axillary orthotropic meristems which developed into chupons that were repeatedly harvested for rooting of stem cuttings. With success at both the establishment of productive stock plants and the rooting of softwood stem cuttings, a comparative test was made to examine the growth and development of clonal orthotropic trees with seedlings for up to one year in the greenhouse. Additionally, juvenile growth of a transgenic line was compared to non-transgenic 2°SE plants, and the first T1 seeds in cacao were produced.

While positive preliminary results were obtained from both systems of stock plant establishment in the greenhouse, there is further need for continued optimization of the techniques applied to further increase production as well as quality of softwood orthotropic chupon propagation materials. Various types of softwood stock plants were tested to determine their productivity. Both 1°SE and 2°SE were utilized. Additionally, each of these was further divided into plants that had undergone an *in vitro* micropropagation step. In the single genotype studies and under the conditions reported, there were no differences detected in the type of materials adapted to softwood stock plant production. This result offers some flexibility to the work being done upstream in the tissue culture laboratory. For example, some genotypes may do poorly under 2°SE or micropropagation. If so, these steps may be skipped, and 1°SE plants may be acclimated and established as stock plants without loss of productivity resulting from some advantage gained through further *in vitro* steps. However, if circumstances necessitate the delay of establishment of SE stock plants, these *in vitro* protocols for 2°SE and micropropagation will allow for the further multiplication of aseptic materials ready for acclimation at the appropriate time without negatively affecting stock plant production.

Softwood stock plants offer a means to begin rapidly greenhouse propagation of orthotropic rooted stem cuttings as soon as two months post-acclimation. While this lessening of time between *ex vitro* establishment and further clonal propagation may be advantageous in some circumstances, care must be taken when making this decision. Firstly, maintaining softwood stock plants requires more attention to greenhouse growing conditions than that for bent semi-hardwood stock plants. As softwood stock plants are smaller than bent semi-hardwood stock plants, they are more susceptible to stresses that may result from inconsistencies in the greenhouse environment or management. In contrast, the greater robustness of bent semi-hardwood stock plants is an advantage in this aspect, although the lag time necessary for growth of a sufficiently developed trunk prior to bending may be unduly long in some instances when more rapid multiplication of limited materials is desired.

Chupons derived from the two different stock plants differed. Chupons from softwood stock plants were of smaller stem diameter and had shorter leaf laminae than those from bent semi-hardwood stock plants. These differences may negatively affect the rooting efficiency (% rooting), particularly the high success obtained in softwood stem cuttings from softwood stock plants. If a highly efficient propagation protocol is not consistently maintained, these smaller stem cuttings will be more negatively affected than the larger stem cuttings from bent semi-hardwood stock plants. Therefore, if it is expected that conditions throughout the year may change significantly, the choice of stem cuttings from bent semi-hardwood stock plants may be a more practical choice in the propagation house.

The long-term cultural management of stock plants will need more investigation to more thoroughly establish this new method of maintaining intensive orthotropic clonal gardens. As well, rooted cuttings derived from stock plants may be converted into their own stock plants. This process was not undertaken in the current study. However, the orthotropic rooted cutting stock plant will play an important role in any long-term strategy to maximize efficiency when bulking up the numbers of stock plants in production. Orthotropic rooted cuttings from softwood stock plants may be converted into softwood or semi-hardwood stock plants, and likewise, orthotropic rooted cuttings from bent semi-hardwood stock plants may be converted into either softwood and/or bent semi-hardwood stock plants. As well, it is expected that a stock plant will come to the end of its utility when either the quality and/or quantity of cuttings produced ebbs. Periodically, old stock plants may be replaced in the production facility by newly established stock plants to maintain clonal garden production levels. This renovation of the clonal garden should be considered for both softwood and semi-hardwood stock plants.

All SE plants, both from 1°SE and 2°SE and their rooted cuttings, formed an orthotropic trunk, jorquette, and normal canopy. As well, these orthotropic plants developed tap root and framework root systems. A tap or framework root system should be an advantage in tree anchorage as well as in increasing rooting at soil depth. Improved tree anchorage may help trees resist felling in instances of high winds. As well, trees with deeper roots would be expected to avert soil moisture deficit at or near the soil surface during times of low rainfall or drought. As concern rises over changes in weather patterns due to climate change, the stresses place on trees in the field would be expected to



increase in both frequency and magnitude, and increased attention may be placed on a clonal propagation method wherein the tap root or framework root system, as well as a desired scion, is consistently produced.

Juvenile 1°SE, 2°SE, and the orthotropic rooted cuttings grown up to one year in the greenhouse allocated growth to leaves, stems, and roots differently than the seminal plants. Allometric analysis of leaf DW to plant DW indicated no differences in the distribution of growth among the treatments. However, allometric analysis of root DW to total plant DW indicated a significant difference in the slightly greater allometric coefficient (K) of seedlings compared to other treatments. As the intercept for seedlings remained below that for the other treatments, a diminishing difference was noted in the greater relative allocation to roots in the cloned plants compared to seedlings as the plants developed. This very interesting result may be due in part to the auxins applied to the cloned plants. The IBA was used in the SE protocol and applied in combination with NAA during the rooting of stem cuttings. The resulting increased relative allocation to the root systems may give these cloned plants an advantage when transplanted into the field, as a relatively more well-established root system may be expected to better support improved transport of water and nutrients to the same leaf area in plants of the same size as compared to seedlings. This area of study merits further investigation, particularly when considering the many problems historically encountered with field establishment of clonal materials relative to seedlings as well as any increase in abiotic stresses expected in cacao growing regions due to climate change.

Rooted cuttings from bent semi-hardwood stock plants had a quick phase change to mature growth and a consequently low jorquette. An orthotropic tree with a low

jourquette may be advantageous for several reasons mentioned earlier, such as facilitating any management activities where access to the canopy is required. Harvesting, pruning, monitoring, and treating for pests and disease may be facilitated in fields composed of trees with low canopies. If the canopy develops quickly, light interception to the soil surface should be reduced. This may alleviate soil moisture loss as well as reduce weed growth- both particularly important aspects in newly established plantings. As well, the need for shape pruning and propping up commonly practiced in plagiotropic rooted cuttings during establishment may be reduced or eliminated with orthotropic trees.

Seminal trees, both bred and selected by breeders as well as heirloom varieties shared among growers, comprise the vast majority of cacao in production systems. While these plants have wide popularity among breeders and growers for their intrinsic values discussed earlier in Chapter 1, seminal trees inefficiently utilize valuable planting area and resources. Development and utilization of clonal varieties improves efficient use of land and other resources, and biotechnology has an important role to play in this goal. However, as with all nascent technologies, preliminary results must be confirmed and repeated to establish their veracity among the research community, the growers, and the public. To this end, several field experiments have been established to follow SE-derived cacao. But, as with all activities involving tree crop improvement, progress can be slow due to the extended evaluation times. As well, many of the technologies addressed in this study have been developed at temperate latitudes, while cacao is grown exclusively at tropical latitudes. This spacial disjunction can add to the challenge of rapidly transitioning laboratory results into field evaluations. However, much progress has been made in this arena over the last decade. While several field tests to examine the relatively

new somatic embryogenesis technology in cacao have been established, few reports have been made as to their long-term performance. Moreover, there is a paucity of studies that comparatively examine different vegetative propagation methods in cacao, be that using traditional plant propagation techniques or that from tissue culture. The Pennsylvania State University research team has reported in detail on the development of an integrated *in vitro* and greenhouse orthotropic vegetative propagation system for cacao. As well, the first field observations have recently been published from comparison of early production in seminal and clonal cacao derived from somatic embryogenesis and micropropagation, as well as orthotropic rooted cuttings from bent semi-hardwood stock plants taken from tissue culture. The results from the current greenhouse-based research add another chapter to this newly growing body of knowledge in the next generation of vegetative propagation in cacao.

## LITERATURE CITED

- Adomako, B., Adu-Ampomah, Y. 2000. Reflections on the yield of Upper Amazon cocoa hybrids in Ghana with reference to breeding for cocoa swollen shoot virus resistant varieties. *Cocoa Growers' Bulletin*, 50: 33-45.
- Adomako, B., Adu-Ampomah, Y. 2003. Assessment of the yield of individual cacao trees in four field trials. In: F. Bekele, M.J. End, A.S. Eskes (eds.). *Proceedings of the International Workshop on Cocoa Breeding for Improved Production Systems*. 19<sup>th</sup> – 21<sup>st</sup> October 2003, Accra, Ghana, 41-49.
- Adu-Ampomah, Y., Novak, F.J., Afza, R., van Duren, M. 1992. Meristem-tip culture of cocoa (*Theobroma cacao* L.). *Tropical Agriculture (Trinidad)*, 69(3): 268-272.
- Ahenkorah, Y. 1975. Use of radio-active phosphorous in determining the efficiency of fertilizer utilization by cacao plantation. *Plant and soil*, 42: 429-439.
- Alemanno, L., Berthouly, M., Michaux-Ferrière, N. 1996a. Embryogenèse somatique de cacaoyer á partir de pièces florales. *Plantations Recherche Developpement*, 3: 225-233.
- Alemanno, L., Berthouly, M., Michaux-Ferrière, N. 1996b. Histology of somatic embryogenesis from floral tissues of cocoa. *Plant Cell Tissue and Organ Culture*, 46: 187-194.
- Alemanno, L., Berthouly, M., Michaux-Ferrière, N. 1997. A comparison between *Theobroma cacao* L. zygotic embryogenesis and somatic embryogenesis from floral explants. *In Vitro Cellular and Developmental Biology – Plant*, 33: 163-172.

- Almeida, A.-A.F., Valle, R.R., Minar, P.S. 1998. Photosynthesis and associated metabolism during development of a *Theobroma cacao* hybrid with the lethal factor *Luteus-Pa*. *Photosynthetica*, 35(1): 47-60.
- Alvim, P. de T., Duarte, O., Castro, H., Nascimento, I. 1954. Mejores preparaciones hormonales para el enraizamiento de las estacas de cacao. *Turrialba*, 4(3-4): 147-154.
- Amefia, Y.K., Cilas, C., Djiekpor, E.K., Partiot, M. 1985. Vegetative propagation of the cocoa tree. Note on a method for obtaining cuttings with orthotropous rooting. *Café Cacao Thé*, 29(2): 83-88.
- Anonymous. 1933. Cacao Research. *Tropical Agriculture*, 10(8): 209-211.
- Anonymous. 1934. Cacao Research. *Tropical Agriculture*, 11(6): 129-131.
- Anonymous. 1937. Efficient cacao production. *Tropical Agriculture*, 14(6): 161-162.
- Antúnez de Mayolo, G., Maximova, S.N., Pishak, S., Gultinan, M.J. 2003. Moxalactam as a counter-selection antibiotic for *Agrobacterium*-mediated transformation and its positive effects on *Theobroma cacao* somatic embryogenesis. *Plant Science*, 164: 607-615.
- Archibald, J.F. 1954. Culture *in vitro* of cambial tissue of cacao. *Nature*, 173: 351 – 352.
- Archibald, J.F. 1955. The propagation of cacao by cuttings. Technical Bulletin No. 3, West African Cocoa Research Institute, 3-6.
- Atanda, A.O., Toxopeus, H. 1971. A proved case of heterosis in *Theobroma cacao* L. III International Cocoa Research Conference, Accra, Ghana, 23-29 November 1969, Cocoa Research Institute, Tafo, Ghana, 1971: 545-551.
- Bahaudin, J., Maulud, A.R., Hambali, A. 1984. Evaluation of several mature budding techniques of cocoa. International Conference on Cocoa and Coconuts, 1-10.

- Baker, R.E.D. 1950. West Indian cacao research- a progress report. *Tropical Agriculture Trinidad*, 27: 227-230.
- Bartley, B.G.D. 1970. Yield variation in the early productive years in trials with cacao (*Theobroma cacao* L.). *Euphytica*, 19: 199-206.
- Barton, L.V. 1965. Viability of seeds of *Theobroma cacao* L. *Contributions From Boyce Thompson Institute*, 23: 109-122.
- Batista, L.J. 1981. Assessment of the productive capacity of 6 cacao hybrids in the Dominican Republic. *Proceedings of the 8<sup>th</sup> International Cocoa Research Conference, Cartagena, Colombia*, 713-717.
- Bekele, F., End, M.J., Eskes, A.B. (eds.). 2003. Workshop synthesis, conclusions and recommendations. *Proceedings of the International Workshop on Cocoa Breeding for Improved Production Systems, 19<sup>th</sup>-21<sup>st</sup> October 2003, Accra, Ghana, INGENIC and COCOBOD*, 1-10.
- Bertrand, B. 1987. Some aspects of propagation of cocoa (*Theobroma cacao* L.) by micro-cuttings. *Café Cacao Thé*, 31(3): 175-182.
- Bertrand, B., Agbodjan, A.K. 1989. Propagation of cocoa by orthotropic cuttings. Initial results and prospects. *Café Cacao Thé*, 33(3): 147-156.
- Bertrand, R., Dupois, V. 1992. Contribution to the development of cloning in *Theobroma cacao* utilizing orthotropic axes. Constraints and prospects. *Café Cacao Thé*, 36(1): 9-26.
- Bolstad, P.V., Libby, W.J. 1982. Comparisons of radiata pine cuttings of hedge and tree-form origin after seven growing seasons. *Silvae Genetica*, 31(1): 9-13.

- Bowman, G.F. 1948. Rooting cacao cuttings- an improved method. Cacao Information Bulletin, Turrialba, 1(5): 1-2.
- Brooks, E.R., Guard, A.T. 1952. Vegetative anatomy of *Theobroma cacao*. Botanical Gazette, 113: 444-454.
- Charrier, A. 1969. Contribution to the study of the morphogenesis and vegetative propagation of cacao (*Theobroma cacao* L.). Café Cacao Thé, 13(2): 97-115.
- Chatelet, P., Michaux-Ferriere, N., Dublin, P. 1992. Potentialites embryogenes du nucelle et du tegument interne de graines immatures de cacaoyer (*Theobroma cacao* L.). Comptes Rendus de l'Academie des Sciences Serie III- Sciences de la Vie- Life Sciences, Paris, 315(2): 55-62.
- Cheesman, E.E. 1934. The vegetative propagation of cacao. Empire Journal of Experimental Agriculture, 11(2): 40-52.
- Cheesman, E.E. 1935. The vegetative propagation of cacao. Tropical Agriculture, 12(9): 240-246.
- Cheesman, E.E. 1936. The vegetative propagation of cacao. VII. Root systems of cuttings. Fifth Annual Report on Cacao Research 1935, Trinidad: pg. 7, plates 3 & 4.
- Cheesman, E.E. 1940. General notes on field experiments CRB 1 to CRB 6. Tenth Annual Report on Cacao Research, 1940, Trinidad: 3-11.
- Cheesman, E.E. 1945. Field experiments in cacao research, 1943-44. Tropical Agriculture, 22(4): 64-66.
- Cheesman, E.E. 1946a. Results of cacao experiments in 1944-45. Tropical Agriculture, 23(4): 63-65.

- Cheesman, E.E. 1946b. The utilization and future of clonal cacao. *Tropical Agriculture*, 23(5): 86-88.
- Cheesman, E.E. 1948. Yields in cacao experiments 1945-46. *Tropical Agriculture*, 25(1-12): 14-18.
- Cheesman, E.E., Pound, F.J. 1932. Uniformity trials on cacao. *Tropical Agriculture*, 9(9): 277-287.
- Cheesman, E.E., Spencer, G.E.L. 1940. The cost of cacao propagation. *Tropical Agriculture*, 17(9): 163-165.
- Cilas, C., Amefia, Y.K., Legrand, B., Pelissou, H. 1985. Study on the stability of the productivity character in the cocoa tree. First findings and breeding prospect. *Café Cacao Thé*, 29(2): 89-94.
- Cope, F.W. 1949. Some results of the cacao clonal trials at River Estate, Trinidad. Report of the Cocoa Conference, Grosvenor House, London, 30 July – 1 August, 1949, The Cocoa, Chocolate and Confectionary Alliance Limited, 86-88.
- Cope, F.W., Murray, D.B. 1952. A stock scion experiment with cacao progress report. Report on Cacao Research 1952, Trinidad, 34-35.
- Cope, F.W., Jolly, A.L. 1955. West Indian clones. Report of the Cocoa Conference held at Grosvenor House, London, W.1, 15 to 15 September, 1955, 58-66.
- Cruz, M., Whitkus, R., Gómez-Pompa, A., Mota-Bravo, L. 1995. Origins of cacao cultivation. *Nature*, 375: 542-543.
- Cuatrecasas, J. 1964. Cacao and its allies, a taxonomic revision of the genus *Theobroma*. *Contributions to the U. S. National Herbarium*, 35(6): 379-614.



- Deng, X., Joly, R.J., Hahn, D.T. 1989. Effects of plant water deficit on the daily carbon balance of leaves of cacao seedlings. *Physiologia Plantarum*, 77: 407-412.
- Dias, L.A.S. 2001. Novos rumos no melhoramento. In: *Melhoramento Genético do Cacaueiro*, L.A.S. Dias (ed.) Editora Folha de Viçosa Ltda, Viçosa, Minas Gerais, Brazil: 531-578.
- Dodds, K.S., Cope, F.W. 1951. Field experiments with clonal cacao. *Journal of Horticultural Science*, 26(4): 249-260.
- Duguma, B., Gockowski, J., Bakala, J. 2001. Smallholder cacao (*Theobroma cacao* Linn.) cultivation in agroforestry systems of West and Central Africa: challenges and opportunities. *Agroforestry Systems*, 51: 177-188.
- Efron, Y. 1998. Orthotropic (chupon) budding. *Ingenic Newsletter*, 11-13.
- Efron, J. 1999. Factors affecting jorquette height in orthotropic buddings. *Ingenic Newsletter*, 5: 11-15.
- Efron, Y., Epaina, P., Faure, M., Marfu, J. 2000. Accelerated cocoa hybrid clones development programme in Papua New Guinea. *Proceedings of the 13<sup>th</sup> International Cocoa Research Conference*, October 9-14, 2000, Kota Kinbalu, Sabah, Malaysia, 31-40.
- Efron, Y., Epaina, P., Taisa, S. 2003. Analysis of the factors affecting yield and yield variability in the SG2 cocoa hybrid variety in Papua New Guinea. In: F. Bekele, M.J. End, A.S. Eskes (eds.) *Proceedings of the International Workshop on Cocoa Breeding for Improved Production Systems*. 19<sup>th</sup> – 21<sup>st</sup> October 2003, Accra, Ghana, 50-61.

- Esan, E.B. 1977. Tissue culture studies on cacao (*Theobroma cacao* L.). A supplementation of current research. Proceedings of the 5<sup>th</sup> International Cacao Research Conference, 1975, Ibadan, Nigeria, 116-125.
- Esan, E.B. 1992. Micropropagation of Cocoa (*Theobroma cacao* L.). In: Biotechnology in Agriculture and Forestry, Vol. 18. High-Tech and Micropropagation II. Y.P.S. Bajaj ed. Springer-Verlag Berlin Heidelberg, 96-122.
- Eskes, B. 2000. Collaborative activities on cocoa germplasm utilization and conservation supported by the CFC/ICCO/IPGRI project. Proceedings of the 13<sup>th</sup> International Cocoa Research Conference, October 9-14, 2000, Kota Kinbalu, Sabah, Malaysia, 23-30.
- Esquivel, O., Soria, V. 1967. Ensayos de campo. CACAO, Informe Anual, Costa Rica, 12(3): 14-20.
- Evans, H. 1951. Investigations on the propagation of cacao. Tropical Agriculture, 28: 147-203.
- Fang, J.Y., Wetten, A., Hadley, P. 2004. Cryopreservation of cocoa (*Theobroma cacao* L.) somatic embryos for long-term germplasm storage. Plant Science, 1663: 669-675.
- Faraway, J.J. 2005. Linear Models with R. Chapman & Hall/CRC, 229pp.
- Figuera, A., Janick, J. 1993. Development of nucellar somatic embryos of *Theobroma cacao*. Acta Horticulturae, 336: 231-238.
- Figuera, A., Janick, J. 1995. Somatic embryogenesis in cacao (*Theobroma cacao* L.). In: Jain, S., Gupta, P., Newton, R., (eds.) Somatic embryogenesis in woody plants, vol. 2. The Netherlands: Kluwer Academic Publishers: 291-310.

- Flores, F., Vera B., J. 1987. Influencia de la fenologia sobre el enraizamiento de ramillas y prendimento de injertos em clones de cacao. 10<sup>th</sup> International Cocoa Research Conference, May 17-23, 2000, Santo Domingo, Dominican Republic, 111-115.
- Florin, B., Brulard, E., Petiard, V. 2000. In vitro cryopreservation of cacao genetic resources. In: Engelman, F., Tagaki, H. (eds.). Cryopreservation of Tropical Plant Germplasm. Japanese International Research Centre for Agricultural Sciences and IPGRI, Rome, 344-347.
- Flynn, W.P., Glicenstein, L.J., Fritz, P.J. 1990. *Theobroma cacao* L.: an axillary bud *in vitro* propagation procedure. Plant Cell, Tissue and Organ Culture, 20(2): 111-117.
- Fontanel, A., Alvarez, M., Favereau, P., Labbé, G., Von Rutte, S., Pétiard, V. 2002. Propagation par embryogenèse somatique de clones de cacaoyers (*Theobroma cacao* L.): conformité des arbres obtenus à partir de cals embryogènes. VIIIèmes Journées Scientifiques du Réseau Biotechnologies, Amélioration des plantes et Sécurité Alimentaire, 7-9 Octobre 2002, Marrakech, Morocco, [page numbers].
- Fordham, R. 1973. Root excavations, River Estate. Annual Report on Cacao Research 1972, Trinidad: 34-37.
- Freeman, W.G. 1929. Results of cacao research at River Estate. Tropical Agriculture, 6: 127-133.
- Glendinning, D.R. 1960. The relationship between growth and yield in cocoa varieties. Euphytica, 9: 351-355.
- Glicenstein, L.J., Flynn, W.P., Fritz, P.J. 1990. Clonal production of cacao. Cocoa Growers' Bulletin, 43: 7-10.

- Greathouse, D.C., Laetsch, W.M. 1969. Structure and development of the dimorphic branch system of *Theobroma cacao*. American Journal of Botany, 56(10): 1143-1151.
- Greathouse, D.C., Laetsch, W.M., Phinney, B.O. 1971. The shoot-growth rhythm of a tropical tree, *Theobroma cacao*. American Journal of Botany, 58(4): 281-286.
- Guiltinan, M. 2007. Cacao. In: Pua, E.-C. and Davey, M. R. (eds.). Biotechnology in Agriculture and Forestry - Transgenic Crops V. Springer, Berlin Heildeberg, Germany, 563 pp.
- Guiltinan, M., Miller, C.R., Traore, A., Maximova, S.N. 2000. Greenhouse and field evaluation of orthotropic cacao plants produced via somatic embryogenesis, micro and macropropagation. Proceedings of the 13<sup>th</sup> International Cocoa Research Conference, October 9-14, 2000, Kota Kinbalu, Sabah, Malaysia, 323-330.
- Hall, T.H.R. 1963. The cuttings production and rooting potential of some W.A.C.R.I. cocoa clones. Tropical Agriculture, 40(3): 223-228.
- Hallé, F. Oldeman, R.A.A., Tomlinson, P.B. (eds.) 1978. Tropical trees and forests an architectural analysis. Springer-Verlag, New York, 441 pp.
- Harland, S.C., Parga, R.G. 1924. The habit of budded cacao. Tropical Agriculture, 1: 132-133.
- Hart, J.H. 1900. Cacao. 2<sup>nd</sup> ed. The 'Mirror' Office, Port of Spain, Trinidad, 117pp.
- Hartmann, H.T., Kester, D.E., Davies, F.T.Jr., Geneve, R.L. (eds.). 1997. Plant propagation: principles and practices, 6<sup>th</sup> edition, Prentice Hall, Upper Saddle River, New Jersey, U.S.A., 770 pp.

- Helfenberger, A. 1987. La producción de cacao en Costa Rica: sus limitaciones y posibilidades para la expansión. CAAP (Consejo Agropecuario Agroindustrial Privado), San José, Costa Rica. (*apud* Hunter, R.J., 1990).
- Hoagland, D.R., Arnon, D.I. 1950. The water culture method for growing plants without soil. California Agricultural Experiment Station Circular, University of California at Berkeley, 347: 1-32.
- Huang, H.-J., Chen, Y., Kuo, J.-L., Kuo, T.-T., Tzeng, C.-C., Huang, B.-L., Chen, C.-M., Huang, L.-C. 1996. Rejuvenation of *Sequoia sempervirens in vitro*: changes in isoesterases and isoperoxidases. *Plant Cell Physiology*, 37(1): 77-80.
- Hunter, R.J. 1990. The status of cacao (*Theobroma cacao*, Sterculiaceae) in the western hemisphere. *Economic Botany*, 44(4): 425-439.
- Irizarry, H., Rivera, E. 1998. Early yield of five cacao families at three locations in Puerto Rico. *Journal of the Agricultural University of Puerto Rico*, 82(3-4): 167-176.
- Jagoret, P., Bertrand, B., Jadin, P. 1992. Pursuit of suitable techniques for cacao replanting in Togo. II. Comparative study of different husbandry techniques under research station conditions. *Café Cacao Thé*, 36(3): 207-212.
- Jain S.M. 2006. An updated overview of advances in somatic embryogenesis in forest trees. In: K. Suzuki, K. Ishii, S. Sakurai, S. Sasaki (eds.) *Plant Technology in Tropical Forest Science*. Springer-Verlag, Tokyo, 113-122.
- Jolly, A.L. 1956. Clonal cuttings and seedlings of cocoa. *Tropical Agriculture*, 33(3): 233-237.
- Joly, R.J., Hahn, D.T. 1989. Net CO<sub>2</sub> assimilation of cacao seedlings during periods of plant water deficit. *Photosynthesis Research*, 21: 151-159.

- Kennedy, A.J., Lockwood, G., Mossu, G., Simmonds, N.W., Tan, G.Y. 1987. Cocoa breeding: past, present and future. *Cocoa Growers' Bulletin*, 38: 7-22.
- Lambert, S.V., Gultinan, M., Maximova, S., Aitken, W.M. 2000. *Ex vitro* propagation via mini-cuttings of acclimated somatic embryo derived cocoa plants. Proceedings of the 13<sup>th</sup> International Cocoa Research Conference, Kota Kinabalu, Sabah, Malaysia, 237-246.
- Lee, M.T. 2000. Recent experiences in field use of cocoa clones for large scale commercial planting in Malaysia: pros and cons. Proceedings of the 'Technical Meeting': State of knowledge on mass production of genetically improved propagules of cocoa, October 19<sup>th</sup> to 23<sup>rd</sup>, 1998, Ilhéus, Bahia, Brazil, 117-121.
- Li, Z., Traore, A., Maximova, S., Gultinan, M.J. 1998. Somatic embryogenesis and plant regeneration from floral explants of cacao (*Theobroma cacao* L.) using thidiazuran. *In vitro Cellular and Developmental Biology – Plant*, 34: 293-299.
- Libby, W.J., Brown, A.G., Fielding, J.M. 1972. Effects of hedging radiata pine on production, rooting, and early growth of cuttings. *New Zealand Journal of Forestry Science*, 2(2): 263-283.
- Litz, R.E. 1986. Tissue culture studies with *Theobroma cacao*. In: Dimick, P.S., (ed.) Cacao biotechnology symposium. Department of Food Science, College of Agriculture, The Pennsylvania State University, University Park PA, 111-120.
- Lopez-Baez, O., Bollon, H., Eskes, A., Petiard, V. 1993. Embryogenèse somatique de cacaoyer *Theobroma cacao* L. á partir de piéces florales. *Comptes Rendus de l'Academie des Sciences Serie III- Sciences de la Vie- Life Sciences*, Paris, 316: 579-584.

- Mason, W.L. Menzies, M.I., Biggin, P. 2002. A comparison of hedging and repeated cutting cycles for propagating clones of *Sitka spruce*. *Forestry*, 75(2): 149-162.
- Masseret, B., Alvarez, M., Fontanel, A., Pétiard, V. 2005. Conformity of cocoa trees produced via somatic embryogenesis. Proceedings of the Malaysian International Cocoa Conference, 18-19 July, 2005, 122-130.
- Maximova, S.N., Alemanno, L., Young, A., Ferriere, N., Traore, A., Gultinan, M.J. 2002. Efficiency, genotypic variability, and cellular origin of primary and secondary somatic embryogenesis of *Theobroma cacao* L. *In Vitro Cellular and Developmental Biology – Plant*, 38: 252-259.
- Maximova, S.N., Miller, C.R., Antúnez de Mayolo, G., Pishak, S., Young, A., Gultinan, M.J. 2003. Stable transformation of *Theobroma cacao* L. and influence of matrix attachment regions on GFP expression. *Plant Cell Reports*, 21(9): 872-883.
- Maximova, S.N., Young, A., Pishak, S., Miller, C., Traore, A., Gultinan, M.J. 2005. Integrated system for propagation of *Theobroma cacao* L. In: Jain, S.M., Gupta, P.K. (eds.) *Protocols for somatic embryogenesis in woody plants*. Springer, Dordrecht, The Netherlands, 209-229.
- Maximova, S.N., Young, A., Pishak, S., Gultinan, M.J. 2008. Field performance of *Theobroma cacao* L. plants propagated via somatic embryogenesis. *In Vitro Cellular and Developmental Biology – Plant*, 44: 487-493.
- McKelvie, A.D. 1956. Cherville Wilt of Cacao I. Pod development and its relation to wilt. *Journal of Experimental Botany*, 7: 252-263.
- McKelvie, A.D. 1956. Vegetative propagation. *Annual Report of the West African Cocoa Research Institute*, 1955-56: 66-68.

- Monteverde-Penso, E.J., Phillips, W., Machado, R., Brown, J.S., Schnell, R., Motamayor, J.C. 2005. Can we select for shorter cocoa plants? *Ingenic Newsletter*, 10:16-19.
- Montserin, B.G. 1945. Vegetative propagation of cocoa by cuttings. Report and Proceedings of the Cocoa Research Conference, May-June 1945, The Colonial Office, London, 148-152.
- Mooleedhar, V. 2000. A review of vegetative propagation methods in cocoa in Trinidad and the implications for mass production of clonal cocoa plants. Proceedings of the 'Technical Meeting': State of knowledge on mass production of genetically improved propagules of cocoa, October 19<sup>th</sup> to 23<sup>rd</sup>, 1998, Ilhéus, Bahia, Brazil, 122-125.
- de Moraes, K.A.T., (ed.) 2001. *Biofábrica: Informativo do Instituto Biofábrica do Cacau*, 1(4): 4pp.
- Murray, D.B. 1961. Systems of training cacao grown from cuttings. Report on Cacao Research 1959-60, Trinidad, 37-39.
- Murray, D.B., Cope, F.W. 1959. A stock-scion experiment with cacao III. Report on Cacao Research 1957-58, Trinidad, 29-35.
- N'Goran, J.A.K., Laurent, V., Risterucci, A.M., Lanaud, C. 2000. The genetic structure of cocoa populations (*Theobroma cacao* L.) revealed by RFLP analysis. *Euphytica*, 115: 83-90.
- Odegbaro, O.A., Adedipe, N.O. 1986. Rooting classification and culture responses of some cacao hybrids. *Turrialba*, 36(2): 197-204.
- Paulin, D., Garzon, I., Alemanno, L. 2007. Clonal propagation by somatic embryogenesis: preliminary results. *INGENIC Newsletter*, 11: 16-19.



- Pence, V.C., Hasegawa, P.M., Janisck, J. 1979. Asexual embryogenesis in *Theobroma cacao* L. Journal of the American Society of Horticultural Science, 104: 145-148.
- Pereira, J.L., Serôdio, M.H., Bezerra, J.L. (eds.). 2000. Proceedings of the 'Technical Meeting': State of knowledge on mass production of genetically improved propagules of cocoa, October 19<sup>th</sup> to 23<sup>rd</sup>, 1998, Ilhéus, Bahia, Brazil, 156 pp.
- Pound, F.J. 1935. Notes on the budding of cacao. Fourth Annual Report on Cacao Research 1934, Trinidad, 3-7.
- Pound, F.J. 1938. Cacao and witches' broom disease (*Marasmius perniciosus*) of South America with notes on other species of *Theobroma*. Trinidad, Port of Spain, 58 pp.
- Pound, F.J. 1943. Cacao and witches' broom disease (*Marasmius perniciosus*). Trinidad, Port of Spain, 16 pp.
- Pound, F.J. 1945. The selection of cocoa trees on the basis of productive efficiency and the requirements of the manufacturers of chocolate. Report and Proceedings of the Cocoa Research Conference, London, May-June: 134-136.
- Purdy, H., Eskes, B. 2002. Rootstocks for cacao. Ingenic Newsletter, 7: 15-16.
- Pyke, E.E. 1932a. Vegetative propagation. Tropical Agriculture, 9(1): 22-27.
- Pyke, E.E. 1932b. The vegetative propagation of cacao. I- A survey of possibilities. Annual Report on Cacao Research, Trinidad, 4-9.
- Pyke, E.E. 1933a. The vegetative propagation of cacao. II softwood cuttings Second Annual Report on Cacao Research, Trinidad, 3-9.
- Pyke, E.E. 1933b. The vegetative propagation of cacao. Cacao Research, 2: 3-9.
- Pyke, E.E. 1933c. The vegetative propagation of cacao. V.- notes on the dimorphic branching habit of cacao. [publication and pages].

- Quainoo, A.K., Wetten, A.C., Allainguillaume, J. 2008. The effectiveness of somatic embryogenesis in eliminating the cocoa swollen shoot virus from infected cocoa trees  
Journal of Virological Methods, 149(1): 91-96.
- Ramadasan, K. 1978. Production of rooted cocoa cuttings under Malaysian conditions.  
Proceedings of the International Conference on Cocoa and Coconuts, Kuala Lumpur, Indonesia, 44-55.
- Ramadasan, K., Ahmad, M.Y., Ahmad, M.S. 1978. Shaping of clonal cocoa plants derived from fan shoots. Proceedings of the International Conference on Cocoa and Coconuts, Kuala Lumpur, Indonesia, 65-92.
- Ramadasan, K., Ahmad, M.Y. 1986. Recent advances in vegetative propagation techniques of *Theobroma cacao* L. under Malaysian conditions. 1984 International Conference on cocoa and coconuts, paper no. 8, 1-15.
- Roussel, M., Couraud, A. 1968. Notes sur le bouturage du cacaoyer à la Station d'Ambanja (republique Malagasy). *Café Cacao Thé* (Paris), 12(3): 215-222.
- Sánchez, M.C., Ballester, A., Vieitaz, A.M. 1997. Reinvigoration treatments for the micropropagation of mature chestnut trees. *Annales des Sciences Forestieres*, 54: 359-370.
- Santos, M. de O., Romano, E., Yotoko, K.S.C., Tinoco, M.L.P., Dias, B.B.A., Aragão, F.J.L. 2005. Characterization of the cacao *somatic embryogenesis receptor-like kinase* (*SERK*) gene expressed during somatic embryogenesis. *Plant Science*, 168: 723-729.
- Shephard, C.Y. 1936. Some economic aspects of cacao production in Trinidad with special reference to the Montserrat district. *Tropical Agriculture*, 13(4): 85-90.

- Shepherd, R., Chong, C.F., Taylor, J.G. 1981. Experiences with nursery budgrafting on cocoa estates in Malaysia. *Cocoa Growers' Bulletin*, 31: 20-29.
- Silva, T.E.R., Cidade, L.C., Alvim, F.C., Cascardo, J.C.M., Costa, M.G.C. 2008. Somatic embryogenesis and plant regeneration in elite clones of *Theobroma cacao*. *Pesquisa Agropecuária Brasileira*, 43(10): 1433-1436.
- Sondhal, M.R., Liu, S., Bellato, C., Bragin, A. 1993. Cacao somatic embryogenesis. *Acta Horticulturae*, 336: 245-248.
- Sondhal, M.R., Sereduk, T.B., Chen, Z., Bellato, C., Liu, S., Bragin C.H. 1994. Somatic embryogenesis and plant regeneration of cacao. US Patent #5.312.801.
- Toxopeus, H. 1970. Seasonal trend of the rooting success of cuttings of cacao clones in Nigeria and the relation with establishment ability. *Euphytica*, 19: 426-429.
- Traore, A., S.N. Maximova, Gultinan, M.J. 2003. Micropropagation of *Theobroma cacao* L. using somatic embryo-derived plants. *In Vitro Cellular and Developmental Biology- Plant*, 39: 332-337.
- Urquhart, D.H. 1961. *Cocoa*. Longmans, London, pp. 88-98.
- Urquhart, D.H. 1963. *Cacao*.- La Habana: Ed. Revolucionaria, pp. 38.
- van Himme, M. 1959. Etude du système racinaire du Cacaoyer. *Bulletine Agriculture Congo Belge, Ruanda-Urundi*, 50(6): 1541-1600.
- van Himme, M. 1960. Le bouturage du cacaoyer, technique d'avenir. *Bulletin D'Information de L'INEAC*, 9: 274-296.
- Villalobos, V., Aguilar, M.E. 1990. Plant regeneration of cacao (*Theobroma cacao* L.) by micrografting somatic embryos. Abstract. *International Congress of Plant Tissue and Cell Culture*, Amsterdam, 140.

Wood, G.A.R. 1985. Propagation. In: Wood, G.A.R., Lass, R.A. (eds.) *Cocoa*, 4<sup>th</sup> Edition.  
Blackwell Science, Oxfordshire, U.K., 93-118.

**VITA**  
**CARTER R. MILLER**  
Ilhéus, Bahia, Brazil

**EDUCATION**

Ph.D. The Pennsylvania State University, University Park, PA, Horticulture, May 2009.  
M.Sc. The Pennsylvania State University, University Park, PA, Horticulture, Dec. 1998.  
B.S. The University of Oklahoma, Norman, OK, Botany, May 1992.

**PUBLICATIONS**

- Maximova, S.N. ; Young, A.; Pishak, S.; **Miller, C.R.**; Traore, A.; Guiltinan, M.J. 2005. Integrated system for propagation of *Theobroma cacao* L. In: Jain, S.M. and Gupta, P.K. (eds.). Protocol for Somatic Embryogenesis in Woody Plants. Dordrecht: Springer, 77: 209-229.
- Miller, C.R.**; Guiltinan, M.J. 2003. Perspectives on Rapid Vegetative Multiplication for Orthotropic Scion and Rootstock Varieties of Cocoa. In: Bekele, F., End, M.J., Eskes, A.B. (eds.) Proceedings of the International Workshop on Cocoa Breeding for Improved Production Systems, 19<sup>th</sup>-21<sup>st</sup> Oct., Accra, Ghana, 189-194.
- Miller, C.R.**; Ochoa, I.; Nielsen, K.L.; Beck, D.; Lynch, J.P. 2003. Genetic variation for adventitious rooting in response to low phosphorus availability: potential utility for phosphorus acquisition from stratified soils. *Journal of Functional Biology*, Australia, 30: 973-985.
- Maximova, S.N.; **Miller, C. R.**; Antúnez, G. A.M.; Pishak, S.; Young, A.; Guiltinan, M.J. 2003. Stable transformation of *Theobroma cacao* L. and influence of matrix attachment regions on GFP expression. *Plant Cell Reports*, 21(9): 872-883.
- Borch, K.; **Miller, C.R.**; Brown, K.M.; Lynch, J.P. 2003. Improved drought tolerance in marigold by manipulation of root growth with buffered-phosphorus nutrition. *Hortscience*, 38(2): 212-216.
- Guiltinan, M., **Miller, C.R.**, Traore, A., Maximova, S.N. 2000. Greenhouse and field evaluation of orthotropic cacao plants produced via somatic embryogenesis, micro and macropropagation. Proceedings of the 13<sup>th</sup> International Cocoa Research Conference, October 9-14, 2000, Kota Kinabalu, Sabah, Malaysia, 323-330.
- Brown, K. M.; **Miller, C.R.**; Kuhns, L.; Beattie, D.J.; Lynch, J. P. 1999. Improvement of rhododendron and forsythia growth with buffered-phosphorus fertilizer. *Journal of Environmental Horticulture*, 17: 153-157.
- Nielsen, K.L.; **Miller, C.R.**; Beck, D.; Lynch, J.P. 1999. Fractal geometry of root systems: Field observations of contrasting genotypes of common bean (*Phaseolus vulgaris* L.) grown under different phosphorus regimes. *Plant and Soil*, 206(2): 181-190.

**PATENT APPLICATIONS**

Processing cocoa beans and other seeds, U.S. Pat. App. No. 20080274234 - <http://appft1.uspto.gov/netacgi/nph-Parser?Sect1=PTO1&Sect2=HITOFF&d=PG01&p=1&u=%2Fnetacgi%2FPTO%2Fsrchnum.html&r=1&f=G&l=50&s1=%2220080274234%22.PGNR.&OS=DN/20080274234&RS=DN/20080274234>

Processing cocoa beans and other seeds, International Pat. App. PCT/US2008/062270 - <http://www.wipo.int/pctdb/en/wo.jsp?WO=2008137577>

**SELF EMPLOYED**

Cocoa Bean Process Innovator – flavor and ingredient development through scientifically redesigned curing methods